

Play Action®

**PLAYSTAR®**

# *Climbing Bar Kit*

## **Safety Guide & Assembly Instructions**



### **Important!**

Intended for residential use by children ages 2 to 10, only on properly installed PlayStar playsets. Before use refer to complete safety guidelines in your original playset, at [www.playstarinc.com](http://www.playstarinc.com), or at 1-888-752-9782.

**We're Here To Help!**

Call Toll Free **1-888-752-9782**  
Customer Service: Monday - Friday, 8:00 A.M. to 5:00 P.M. C.S.T.

**PS 7766**

# SAFETY

- This product is intended for single-family residential use only, by children ages two to ten and a maximum weight of 105 pounds. Any recommendation over 10 years of age or 105 pounds exceeds the upper limits specified in the American Society for Testing and Materials (ASTM) Home Playground Safety Standard. In order for PlayStar to comply with the ASTM Standard, we cannot recommend anyone above these limits.
- It is a misuse of this product when installed or used in places of public assembly such as schools or parks.
- Follow the instructions provided, do not alter its design in any way.
- Construction requires at least two adults capable of heavy lifting.
- Thoroughly read all safety instructions before beginning.
- Children must remain clear of construction site until this product is properly installed and ready for use.
- Save these instructions in the event the manufacturer has to be contacted.

## The Consumer Product Safety Commission provides the following consumer information for your Home Playground Equipment

### Select Protective Surfacing

One of the most important things you can do to reduce the likelihood of serious head injuries is to install shock-absorbing protective surfacing under and around your play equipment. The protective surfacing should be applied to a depth that is suitable for the equipment height in accordance with ASTM F1292. There are different types of surfacing to choose from; whichever product you select, follow these guidelines:

*NOTE: Do not install home playground equipment over concrete, asphalt, packed earth, grass, carpet or any other hard surface. A fall onto a hard surface can result in serious injury or death to the equipment user. Grass and dirt are not considered protective surfacing because wear and environmental factors can reduce their shock absorbing effectiveness. Carpeting and thin mats are generally not adequate protective surfacing. Ground level equipment -- such as a sandbox, activity wall, playhouse or other equipment that has no elevated play surface -- does not need any protective surfacing.*

### Loose-Fill Materials

PlayStar Playsets require fall-height protection from eight feet.

- Maintain a minimum depth of 9 inches of loose-fill materials such as wood mulch / chips, engineered wood fiber (EWF), or shredded/recycled rubber mulch for

equipment up to 8 feet high. NOTE: An initial fill level of 12 inches will compress to about a 9-inch depth of surfacing over time. The surfacing will also compact, displace, and settle, and should be periodically refilled to maintain at least a 9-inch depth.

- Use containment, such as digging out around the perimeter and/or lining the perimeter with landscape edging. Don't forget to account for water drainage.
- Check and maintain the depth of the loose-fill surfacing material. To maintain the right amount of loose-fill materials, mark the correct level on play equipment support posts. That way you can easily see when to replenish and/or redistribute the surfacing.
- **Do not** install loose fill surfacing over hard surfaces such as concrete or asphalt.

### Poured-In-Place Surfaces or Pre-Manufactured Rubber Tiles

You may be interested in using surfacing other than loose-fill materials -- like rubber tiles or poured-in-place surfaces.

- Installations of these surfaces generally require a professional and are not "do-it-yourself" projects.
- Review surface specifications before purchasing this type of surfacing. Ask the installer/manufacturer for a report showing that the product has been tested to the following safety standard: ASTM F1292 *Standard Specification for Impact Attenuation of Surfacing Materials within the Use Zone of Playground Equipment*. This report should show the specific height for which the surface is intended to protect against serious head injury.

This height should be equal to or greater than the *fall height* - vertical distance between a designated play surface (*elevated surface for standing, sitting, or climbing*) and the protective surfacing below - of your play equipment.

- Check the protective surfacing frequently for wear.

### Placement

Proper placement and maintenance of protective surfacing is essential. Be sure to;

- Extend surfacing at least 6 feet from the equipment in all directions.
- For to-fro swings, extend protective surfacing in front of and behind the swing to a distance equal to twice the height of the top bar from which the swing is suspended.

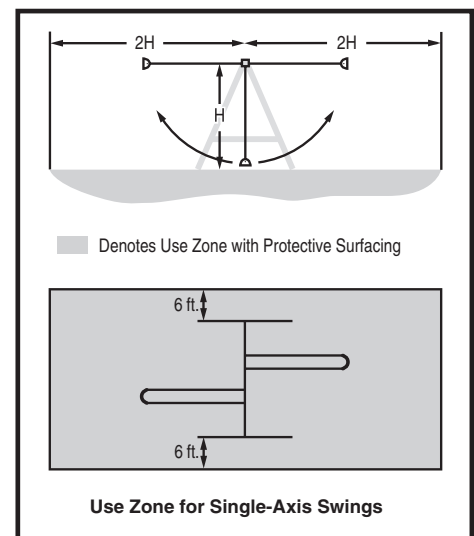

# SAFETY

## INSTALLATION:

1. Follow the instructions provided, do not alter its design in any way.
2. Place the equipment on level ground, not less than 6' (1.8m) from any structure or obstruction such as a fence, garage, house, overhanging branches, laundry lines or electrical wires. If the area where you will be installing your playset is not level, you must make it level.
3. Playsets must be anchored to the ground. Follow the anchoring instructions provided with your building kit. If soil conditions permit anchors to be pulled out easily, such as in sandy soil conditions, cementing is required.
4. Tighten all bolts securely to the intended member then cut off all protruding threaded ends of bolts with a hack saw **flush to the end of the nut** and remove sharp edges with a metal file.

**WARNING:** Children must not use the playset until properly installed and proper shock-absorbing surfacing material is in place.

**OPERATION: Observing and following statements and warnings reduces the likelihood of serious or fatal injury.**

1. On-site adult supervision is recommended for children of all ages.
2. Only one child, for each single planned

seat or single planned activity should be allowed on this set at one time, with a maximum weight of **105 pounds** for each child.

**WARNING:** You must teach children the following:

- A. **Not** to walk close to, in front of, behind, or between moving items.
  - B. **Not** to twist swing chains or ropes or loop them over the top support bar since this may reduce the strength of the chain or rope.
  - C. **Avoid** swinging empty seats.
  - D. **To Sit** in the center of the swings with their full weight on the seats.
  - E. **Not** to use the equipment in a manner other than intended.
  - F. **Not** to get off equipment while it is in motion.
  - G. **Not** to climb when equipment is wet.
  - H. **Not** to attach items to the playground equipment that are not specifically designed for use with the equipment such as, but not limited to, jump ropes, clothesline, pet leashes, cables and chain as they may cause a strangulation hazard.
  - I. **Remove** bike or other sports helmet before playing on the playground equipment.
3. Verify that suspended climbing ropes are secured at both ends and that they cannot be looped back on themselves.
  4. Never add extra length to chain or rope.

The chains or ropes provided are the maximum length designed for the swinging element(s).

5. Dress children appropriately and do not allow them to wear inappropriate items, such as but not limited to, loose fitting clothing, hood and neck draw strings, scarves, cord-connected items, capes, and ponchos. These items can cause death by strangulation. Provide well-fitting and full enclosure footwear. Examples of inappropriate footwear are clogs, flip flops, and sandals.
6. Verify that all suspended swinging components have at least 8" clearance between the lowest point of component and top of shock-absorbing surfacing material.

**WARNING:** Lawn swings are designed for use by children two years of age and older. Use by children under the age of two can result in entrapment between the seat and backrest. **NEVER** place children in a rearward facing position or with legs between the seat and backrest because the child's body may pass through the opening causing entrapment of the child's head.

## DISPOSAL:

When the playset is to be retired from service, disassemble and dispose of in such a way that no unreasonable hazards will exist. Follow your local disposal requirements.



## ANNUAL MAINTENANCE CHECKLIST

(Copy this section as needed and maintain for your records or visit [www.playstarinc.com/maintenance](http://www.playstarinc.com/maintenance))

**At the beginning of play season:** Date: \_\_\_\_\_

- Tighten all hardware.
- Lubricate all metallic moving parts per manufacturer's instructions.
- Check all protective coverings on bolts, pipes, edges, and corners. Replace if they are loose, cracked, or missing.
- Check all moving parts including swing seats, ropes, cables, and chains for wear, rust, or other deterioration. Replace as needed.
- Check metal parts for rust. If found, sand and repaint using a non lead-based paint meeting the requirements of 16 CRF 1303.
- Check all wood members for deterioration and splinters. Sand down splinters and replace deteriorating wood members.
- Reinstall any plastic parts, such as swing seats or any other items that were removed for the cold season.
- Rake and check depth of loose fill protective surfacing materials to prevent compaction and to maintain appropriate depth. Replace as necessary.

**Twice a month during play season:** Date: \_\_\_\_\_

- Tighten all hardware.
- Check all protective coverings on bolts, pipes, edges, and corners. Replace if they are loose, cracked, or missing.
- Rake and check depth of loose fill protective surfacing materials to prevent compaction and to maintain appropriate depth. Replace as necessary.

**Once a month during play season:** Date: \_\_\_\_\_

- Lubricate all metallic moving parts per manufacturer's instructions.
- Check all moving parts including swing seats, ropes, cables, and chains for wear, rust, or other deterioration. Replace as needed.

**At the end of each play season or when the temperature drops below 0° F:** Date: \_\_\_\_\_

- Remove plastic swing seats and other items as specified by the manufacturer and take indoors or do not use.
- Rake and check depth of loose fill protective surfacing materials to prevent compaction and to maintain appropriate depth. Replace as necessary.

**Owner shall be responsible for maintaining the legibility of any warning labels. If any of these conditions exist, call 1-888-752-9782 for ordering information. Clean plastic components with warm water and a mild detergent such as dish soap.**

# COMPONENTS INCLUDED (not actual size)

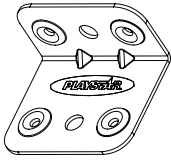

Corner Brackets (4)

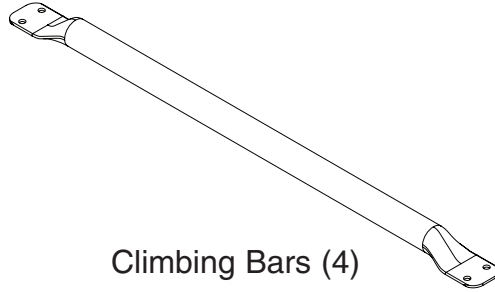

Climbing Bars (4)

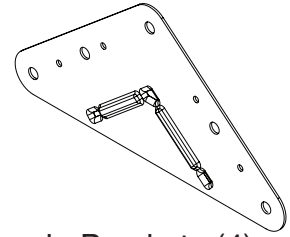

Triangle Brackets (4)

# TOOLS REQUIRED

Level  
Square  
Pencil  
Hammer

Adjustable Wrench  
Socket Wrench  
Drill

Screwdriver (regular or phillips)  
Tape Measure  
Safety Glasses

Sawhorses (optional)  
Shovel  
Ladder

# HARDWARE INCLUDED (shown actual size)

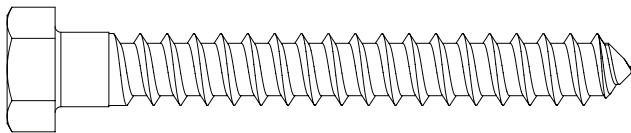

$\frac{3}{8}$ " x 3" Lag Screw (4)

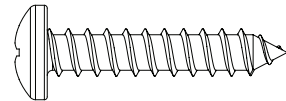

#14 x  $1\frac{1}{4}$ " Pan Head Screw (16)

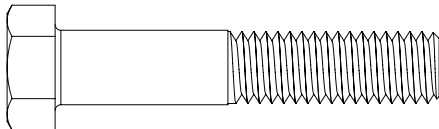

$\frac{3}{8}$ " x 2" Hex Bolt (16)

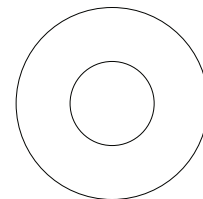

$\frac{3}{8}$ " Washer (8)

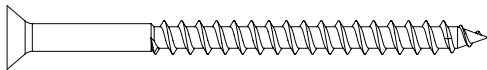

#8 x  $2\frac{1}{2}$ " Deck Screw (15)

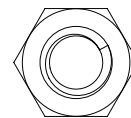

$\frac{3}{8}$ " Lock Nut (16)

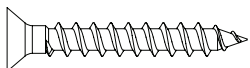

#8 x  $1\frac{1}{4}$ " Deck Screw (32)

NOTE: Depending on your particular application, not all of this hardware may be used.

# LUMBER LIST and CUTTING GUIDE (PURCHASE SEPARATELY)



*Go to Compatibility Chart on page 11 to identify your playset design and locate modification pages. This will help you determine materials required to attach the Climbing Bar Kit.*

2" x 4" x 8' – three (3) boards required for all playsets except Contender and Super Star

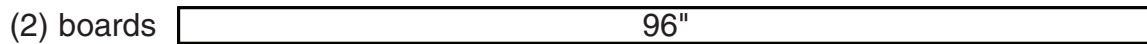

Leg

*Your specific application may require these boards to be cut at a different length. See Page 11 for details*



**When attaching a climbing component/accessory other than climbing bars:**

2" x 4" x 8' – one additional board required for:

- Ridgeline:** Bronze
- Trainer:** All Design Options
- Legacy:** Silver, Bronze, and Starter
- Varsity:** Gold and Silver
- Grand Slam:** Silver, Bronze (see instructions for chosen climbing activity purchased separately), and Starter

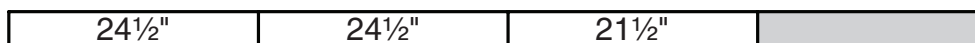

# CLIMBING BAR ASSEMBLY

## Items for **STEP 1:**

- (1) 2" x 4" x 96" board or the length required by your application. (See page 11.)
- (1) 2" x 4" x 46<sup>3</sup>/<sub>4</sub>" board
- (1) triangle bracket
- (4) #8 x 1<sup>1</sup>/<sub>4</sub>" deck screws

On a flat work surface, lay out the 2" x 4" x 96" and 2" x 4" x 46<sup>3</sup>/<sub>4</sub>" boards as shown.

Lay bracket flat on the board. Slide bracket until the stops on the underside are tight against the boards as shown. **(Fig. 1)**

Use the bracket as a drill guide and drill four 1/8" holes 1" deep into the board. Attach with #8 x 1<sup>1</sup>/<sub>4</sub>" deck screws. **(Fig. 2)**

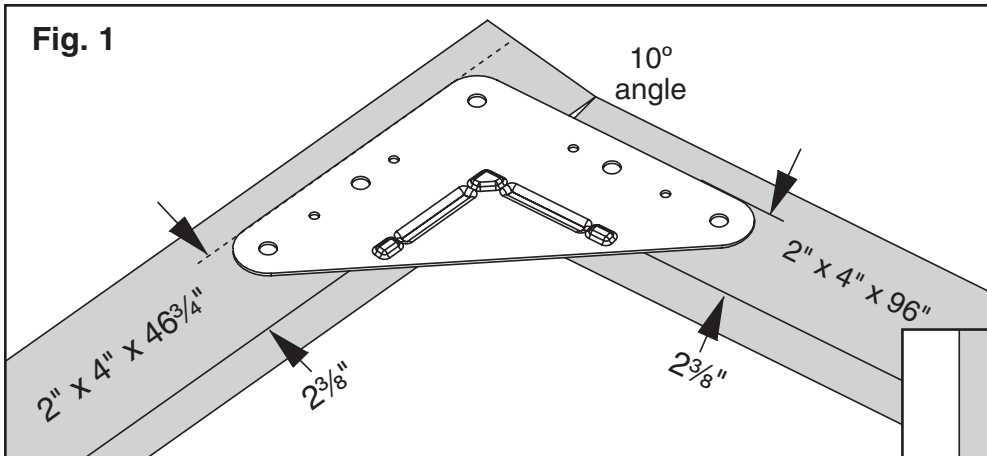

**Helpful Hint:** Mark the two boards at the dimensions shown. This could help to better locate the boards at the correct angle.

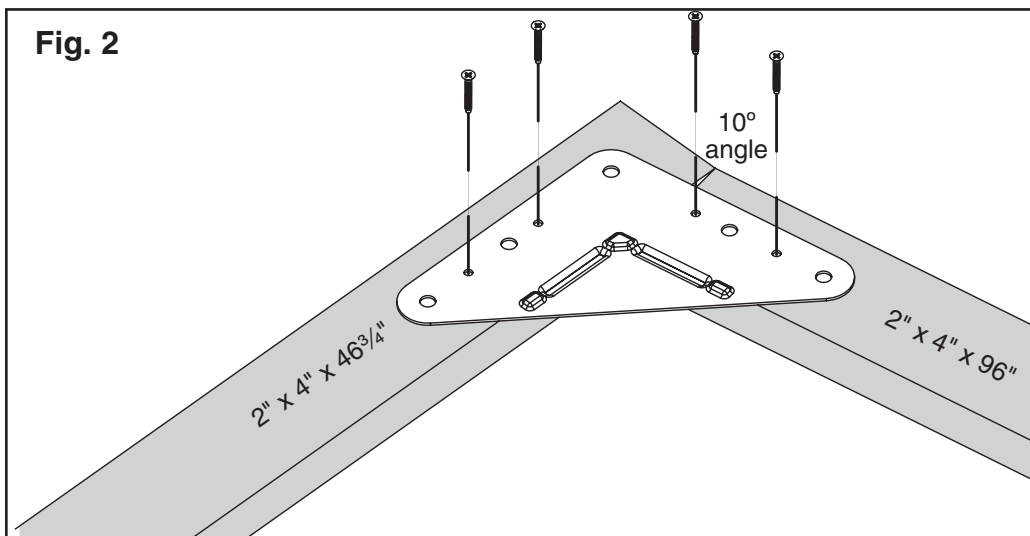
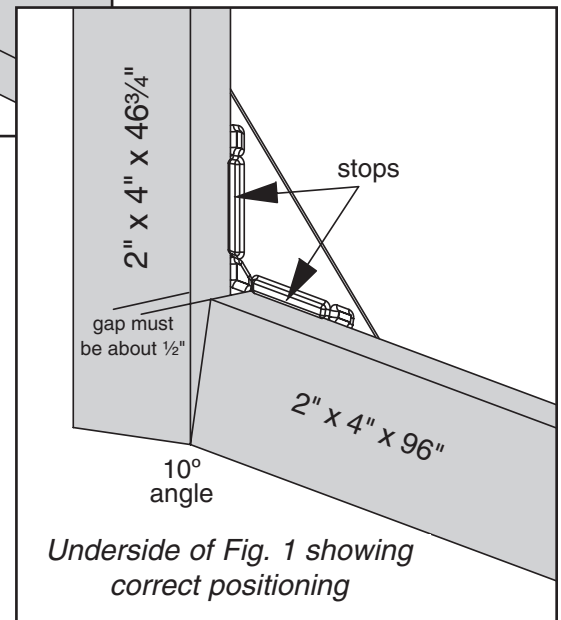

**Items for STEP 2:**

- (1) 2" x 4" x 96" board
- (1) 2" x 4" x 46<sup>3</sup>/<sub>4</sub>" board
- (1) triangle bracket
- (4) #8 x 1<sup>1</sup>/<sub>4</sub>" deck screws

On a flat work surface, lay out the 2" x 4" x 96" and 2" x 4" x 46<sup>3</sup>/<sub>4</sub>" boards as shown.

Lay bracket flat on the board. Slide bracket until the stops on the underside are tight against the boards as shown. **(Fig. 1)**

Use the bracket as a drill guide and drill four 1/8" holes 1" deep into the board. Attach with #8 x 1<sup>1</sup>/<sub>4</sub>" deck screws. **(Fig. 2)**

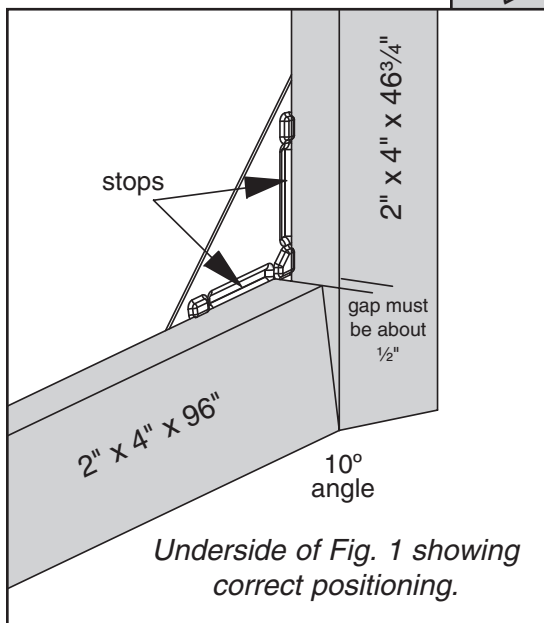
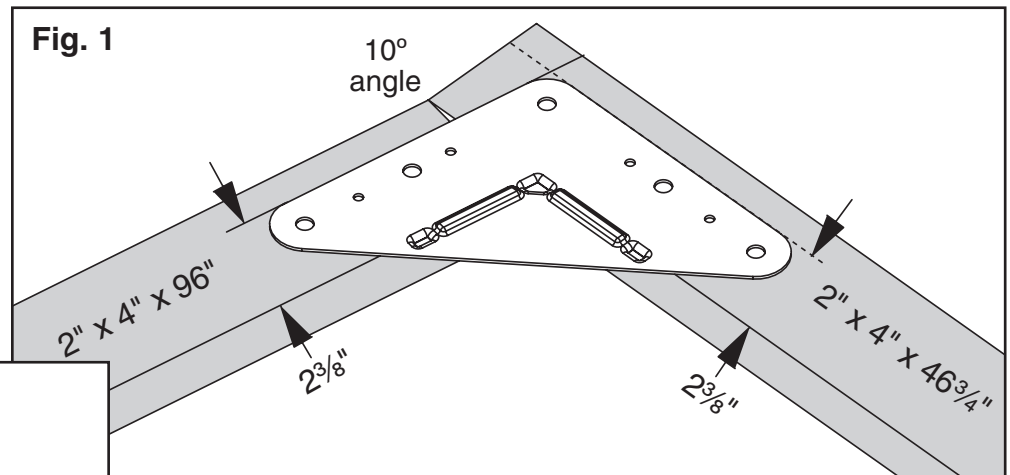

**Helpful Hint:** Mark the two boards at the dimensions shown. This could help to better locate the boards at the correct angle.

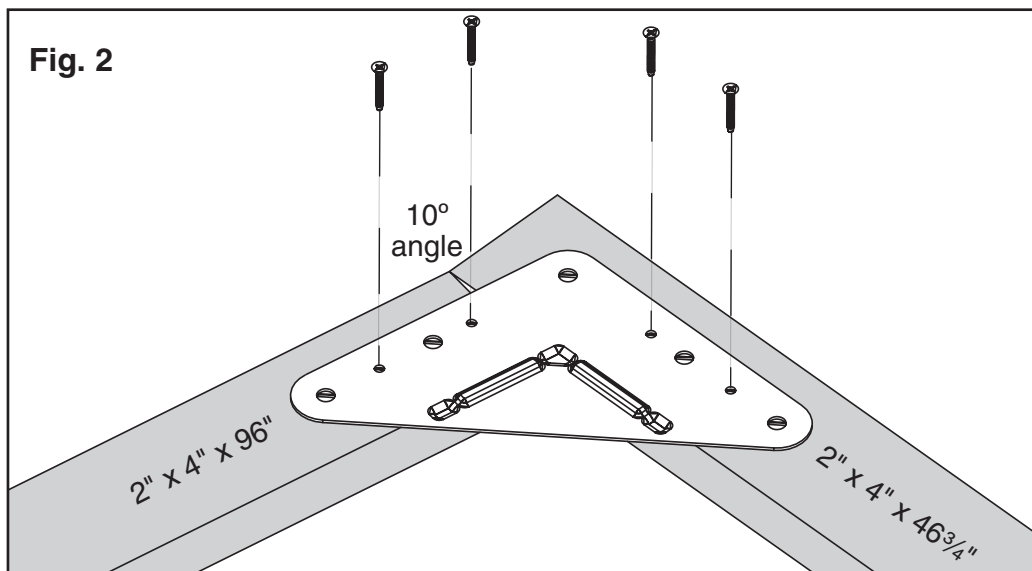

**Items for STEP 3:**

Turn Climbing Bar Assembly over.

- (2) Climbing Bar Assemblies
- (2) Triangle Brackets
- (8) #8 x 1 1/4" deck screws
- (10) 3/8" x 2" hex bolts
- (10) 3/8" lock nuts

Lay bracket flat on the board. Slide bracket until the stops on the underside are tight against the boards as in previous step.

Use the bracket as a drill guide and drill four 1/8" holes 1" deep into the boards. Attach with #8 x 1 1/4" deck screws. **(Fig. 1)**

Use the bracket as a drill guide and drill five 3/8" holes completely through the board. Attach with 3/8" x 2" hex bolts and 3/8" lock nuts. **(Fig. 2)**

Repeat for second Climbing Bar Assembly. **(Figs. 3 & 4)**

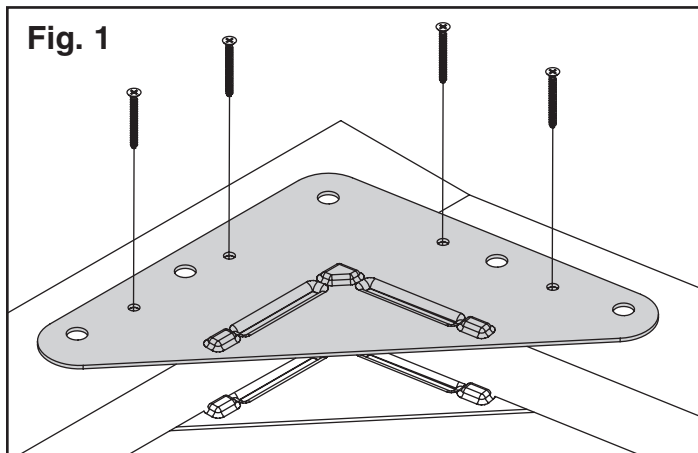

Right Assembly

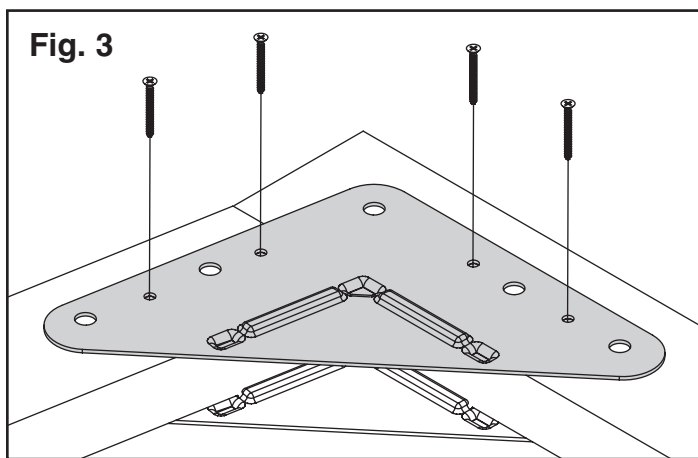
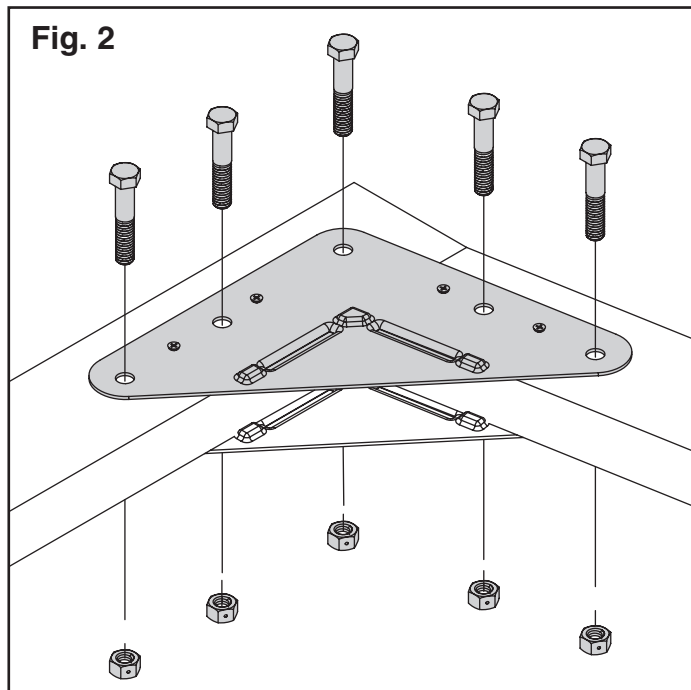

Left Assembly

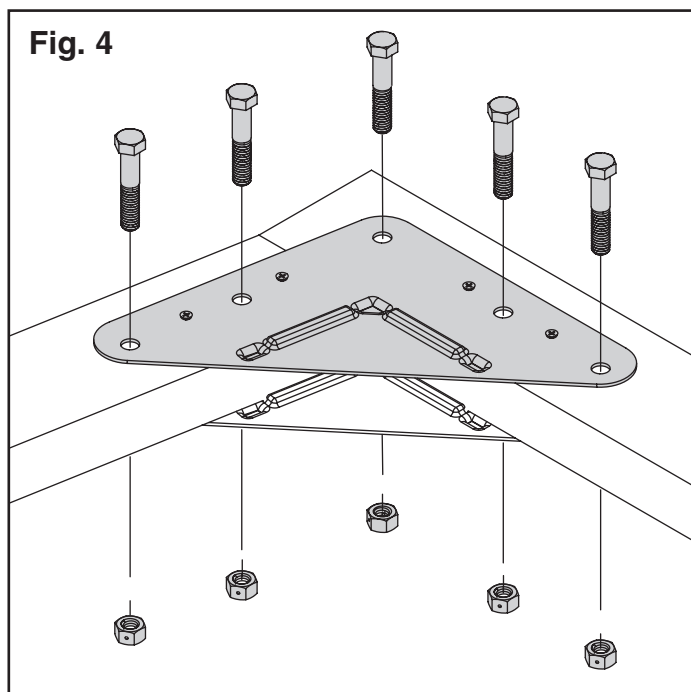



**Items for STEP 4:**

- (4) Climbing Bars
- (16) #14 x 1¼" pan head screws

Attach Climbing Bars at dimensions shown.  
Make sure to keep assemblies 21½" apart.

Use the Climbing Bar as a drill guide and  
drill ⅛" holes 1" deep in the boards

Attach with #14 x 1¼" pan head screws.

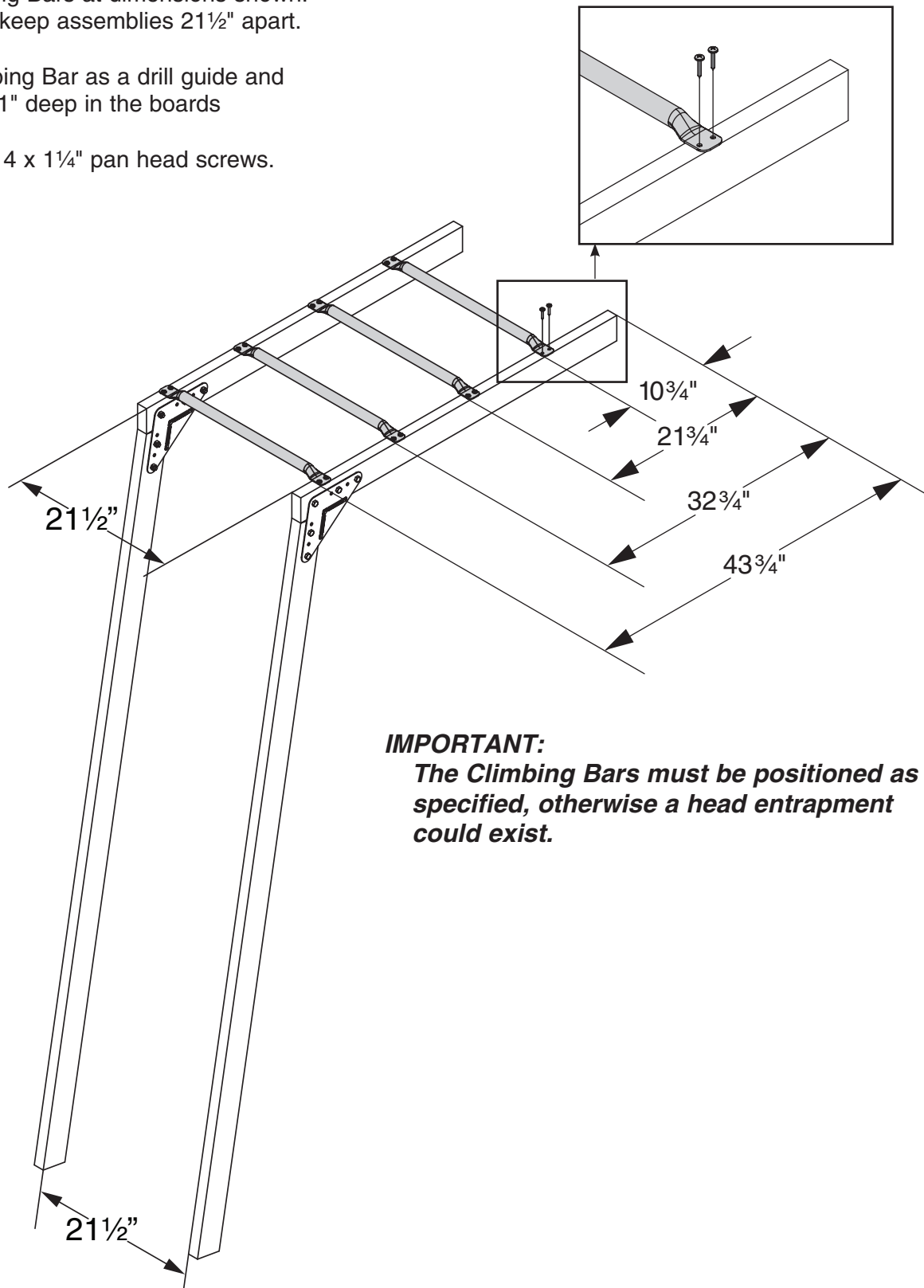

**IMPORTANT:**  
*The Climbing Bars must be positioned as specified, otherwise a head entrapment could exist.*

**Items for STEP 5:**

- (2) corner brackets
- (4) #8 x 1¼" deck screws
- (2) ⅜" x 2" hex bolts
- (4) ⅜" washers
- (2) ⅜" lock nuts

**Attach corner brackets (see details below).**

Position brackets so that the long sides are against the 2" x 4" x 46¾" board and the short side is flush with the end of the board.

Use the bracket as a drill guide and drill ⅛" holes 1" deep into the boards. Attach with #8 x 1¼" deck screws.

Again use the bracket as a drill guide and drill ⅜" holes completely through the boards. Secure with ⅜" x 2" hex bolts, ⅜" washers and ⅜" lock nuts.

Corner brackets must be flush with end of boards.

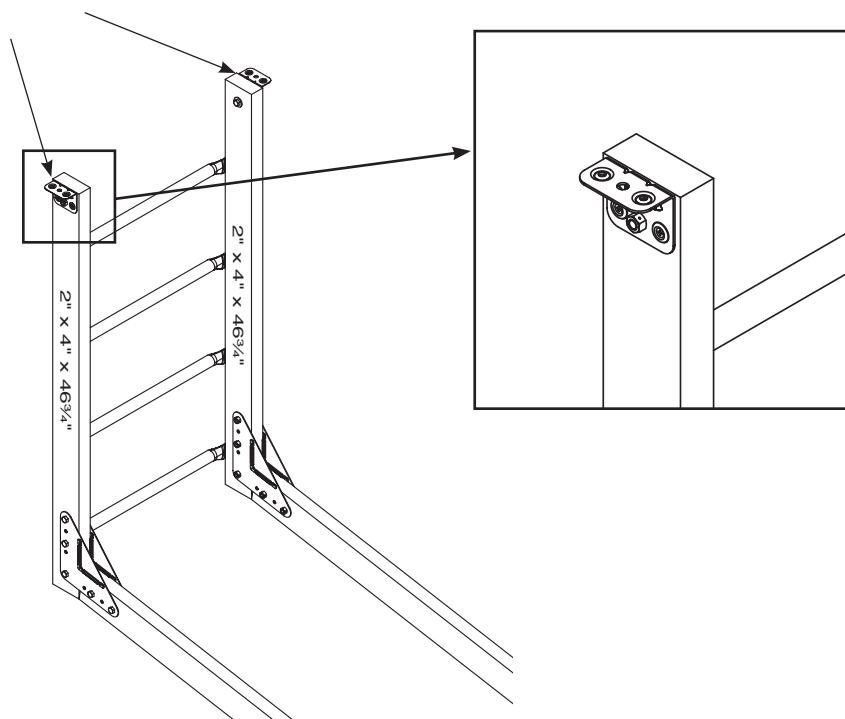





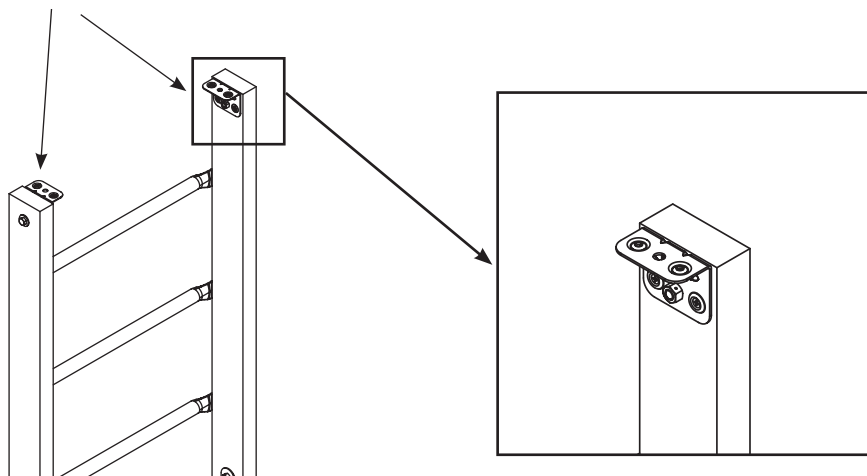



























**Grand Slam Bronze, All-Pro Bronze and Starter and Trainer Silver Only:**

Mount corner brackets flush to the inside as shown.



# CLIMBING BAR KIT COMPATIBILITY

Attach the Climbing Bar Kit to your existing PlayStar playset according to the chart. Place on level ground.

PLAYSET	DESIGN OPTION	TO PLACE CLIMBING BAR, MOVE...	PLAYSET MODIFICATION, SEE PAGE:
<b>Trainer</b>	 Gold	Climbing Steps	12
	 Silver	Climbing Wall	13 & 14
	 Bronze	Swap Rock Wall w/ Vertical Climber	15
	 Starter	Swap Rock Wall w/ Vertical Climber	15
<b>Contender</b>	 Gold	Monkey Ring	16
	 Silver	Monkey Ring	16
	 Bronze	Monkey Ring	16
	 Starter	Monkey Ring	16
<b>Legacy</b>	 Gold	NOT AVAILABLE	NOT AVAILABLE
	 Silver	Climbing Wall	17
	 Bronze	Climbing Steps	18
	 Starter	Vertical Climber	19
<b>SuperStar</b>	 Gold	Monkey Ring	20
	 Silver	Monkey Ring	21
	 Bronze	Monkey Ring	21
<b>RIDGELINE</b>	 Gold	NOT AVAILABLE	NOT AVAILABLE
	 Silver	Included	See Original Ridgeline Instruction
	 Bronze	Swap Rock Wall w/ Vertical Climber	15 (mirror of picture shown)
<b>VARSITY</b>	 Gold	Slide	22
	 Silver	Vertical Climber	22
	 Bronze	Included	See Original Varsity Instruction
	 Starter	NOT AVAILABLE	NOT AVAILABLE
<b>ALLPRO</b>	 Gold	Vertical Climbing Bars	23
	 Silver	Vertical Climbing Bars	23
	 Bronze	Slide	24
	 Starter	Slide	24
<b>GRANDSLAM</b>	 Gold	NOT AVAILABLE	NOT AVAILABLE
	 Silver	Rock Wall	25
	 Bronze	Slide	26
	 Starter	Rock Wall	25
<b>PLATEAU</b>	 Gold	Vertical Climber	Build per this Climbing Bar Instruction, and attach per original Plateau Instruction
	 Silver	Vertical Climbing Bars	
	 Bronze	Vertical Climbing Bars	

NOTE: Climbing Bar Kit only fits a 21½" opening and is designed for PlayStar playsets with a deck height of 48" or 60". Extend Safety Zone and shock-absorbing material a minimum of six feet in all directions from the perimeter of the Climbing Bar Kit, Steps, Rock Walls, and Climbers.

# PLAYSET MODIFICATIONS & CLIMBING BAR ATTACHMENT

## TRAINER - GOLD

Remove Climbing Steps.

### Items for this STEP:

- (4) #8 X 1 1/4" deck screws
- (2) 3/8" x 3" lag screws
- (2) 3/8" washers

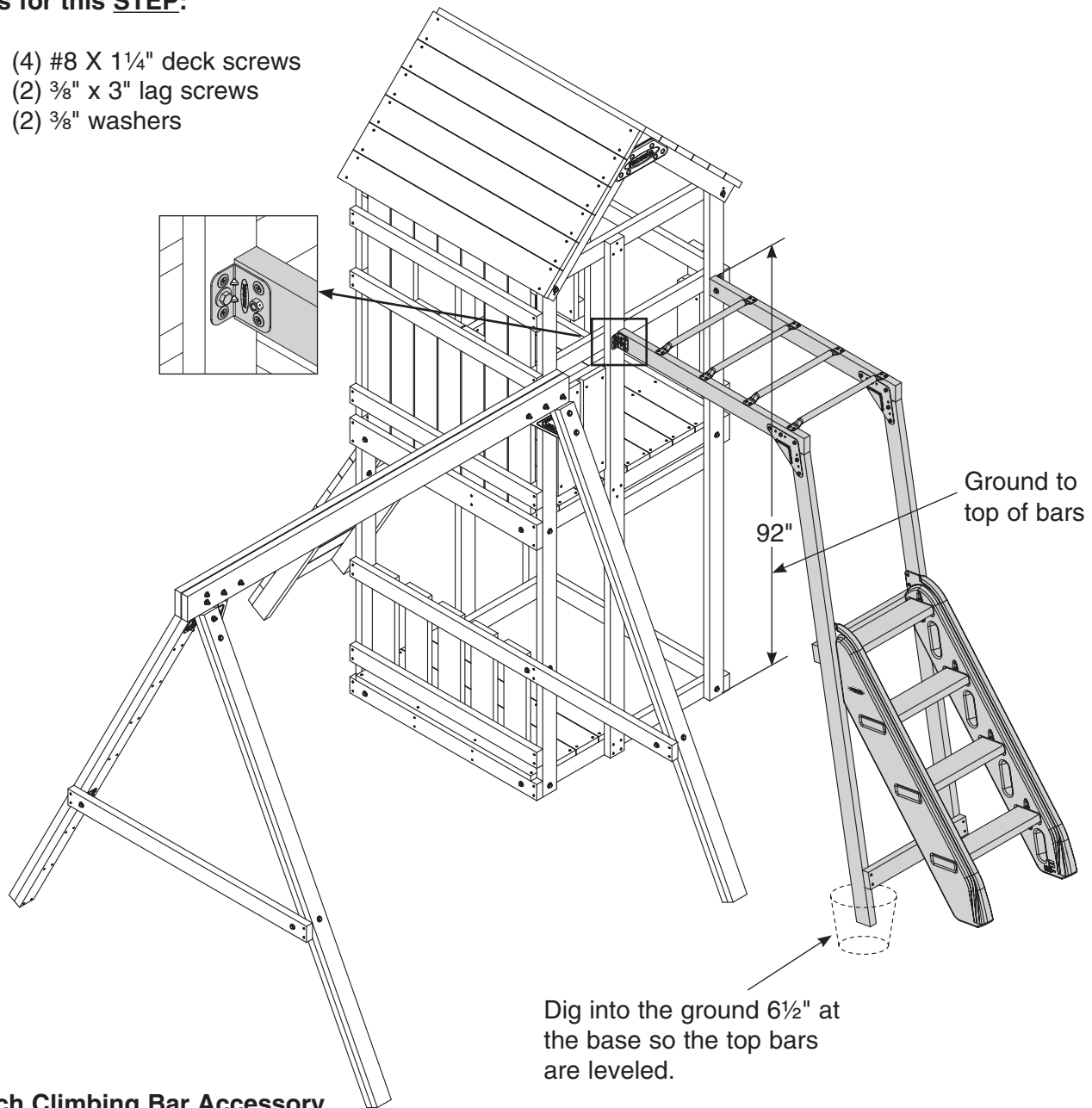

### Attach Climbing Bar Accessory

Lift Climbing Bar Assembly into an upright position at the dimension shown.

Dig into the ground about 6 1/2" at the base so the top bars are leveled.

Use the brackets as a drill guide and drill 1/8" holes 1" deep into the boards. Attach with #8 x 1 1/4" deck screws.

Drill a 1/4" hole 2 1/2" deep into the boards. Secure with 3/8" x 3" lag screw and 3/8" washer.

Go to page 30 for instructions to reattach Climbing Steps.

Go to page 35 for anchoring instructions.

## TRAINER - SILVER

### Items for this STEP:

- (2) Corner Brackets
- (8) #8 x 1 1/4" deck screws
- (2) 3/8" x 3" lag screws
- (2) 3/8" x 2" hex bolts
- (2) 3/8" lock nuts
- (4) 3/8" washers

### Attach Corner Brackets

Position brackets so that the short sides are against the 2" x 4" x 47" board.

Use the brackets as a drill guide and drill 1/8" holes 1" deep into the boards. Attach with #8 x 1 1/4" deck screws.

Use the brackets as a drill guide and drill 1/4" holes 2 1/2" deep through the **long** side and a 3/8" hole completely through the **short** side of the bracket. Secure the **long** side with a 3/8" x 3" lag screw and 3/8" washer. Secure the **short** side with a 3/8" x 2" hex bolt, 3/8" washer and 3/8" lock nut.

Back View

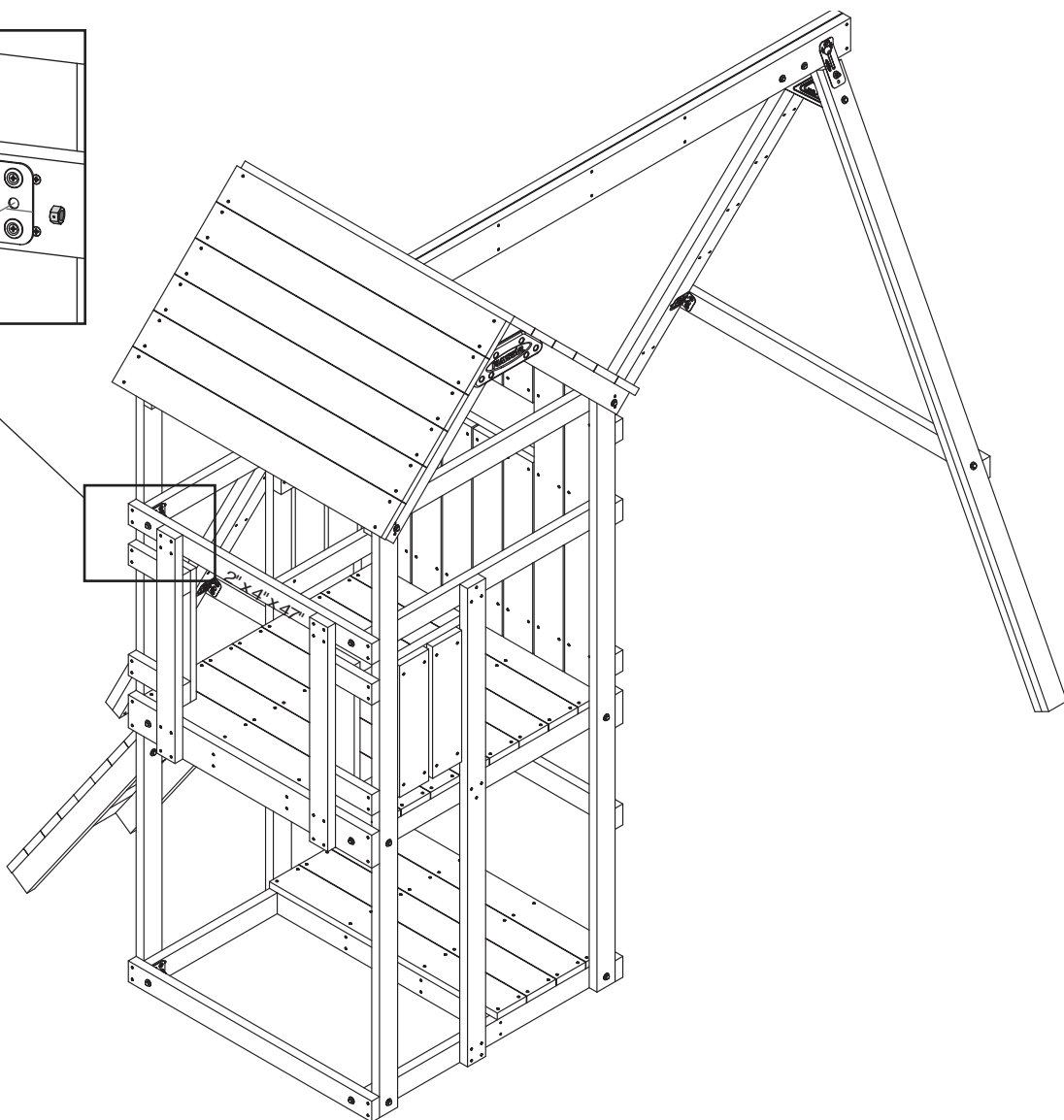
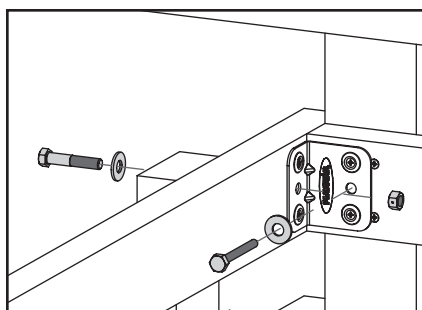

## TRAINER - SILVER

Remove Climbing Wall.

### Items for this STEP:

- (4) #8 x 1¼" deck screws
- (2) ⅜" x 2" hex bolts
- (2) ⅜" washers
- (2) ⅜" lock nuts

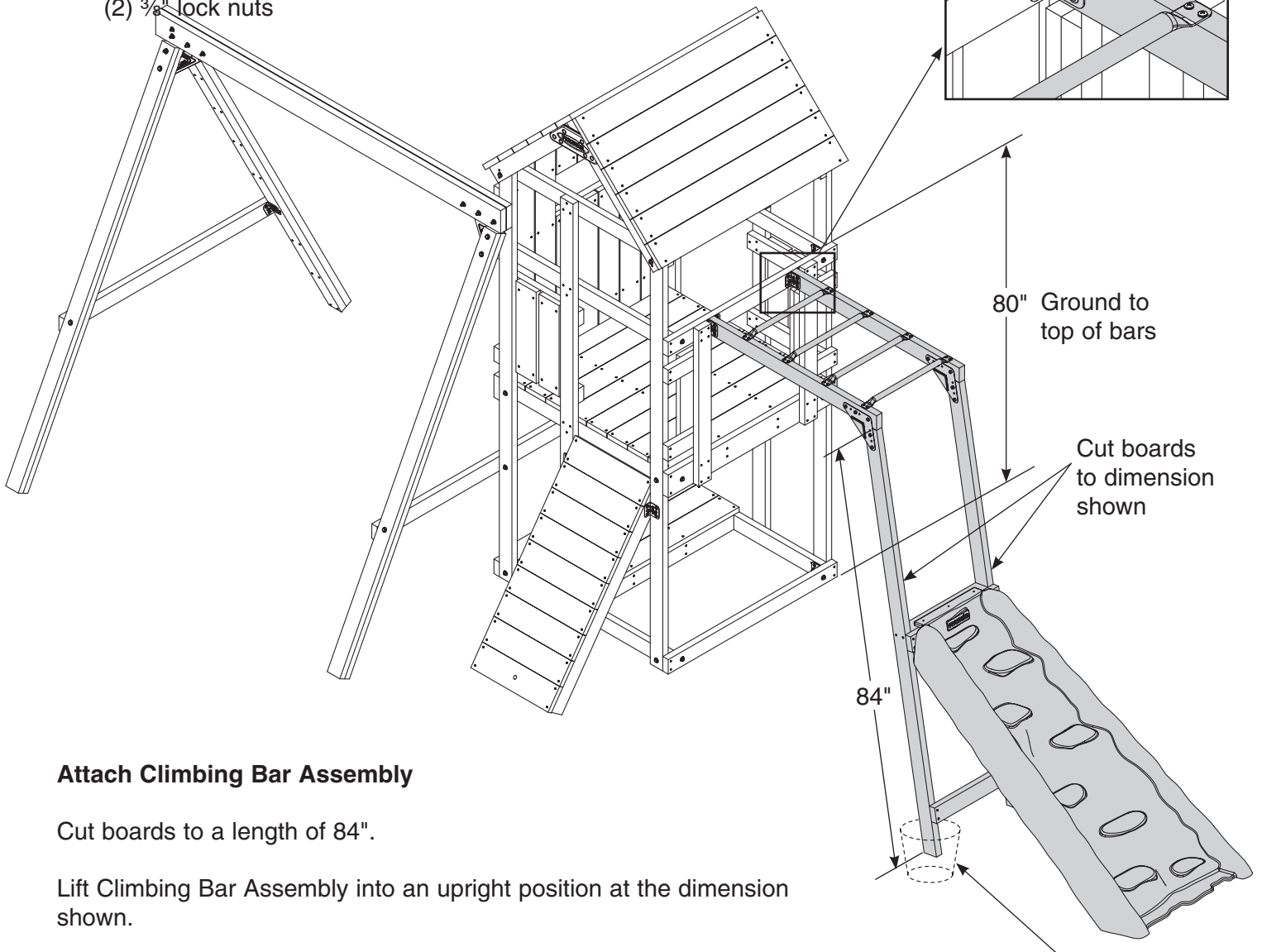

### Attach Climbing Bar Assembly

Cut boards to a length of 84".

Lift Climbing Bar Assembly into an upright position at the dimension shown.

Dig into the ground 6½" at the base so the top bars are leveled.

Use the brackets as a drill guide and drill ⅛" holes 1" deep into the boards. Attach with #8 x 1¼" deck screws.

Drill a ⅜" hole completely through the board. Secure with a ⅜" x 2" hex bolt and ⅜" washer.

**Go to page 28 for instructions to reattach Climbing Wall.**

Dig into the ground 6½" at the base so the top bars are leveled.

**Go to page 35 for anchoring instructions.**

## **TRAINER - BRONZE & STARTER**

### **Items for this STEP:**

- (4) #8 x 1¼" deck screws
- (2) ⅜" x 3" lag screws
- (2) ⅜" washers

Remove Vertical Climber.  
Remove Rock Wall and  
attach to opposite side  
as shown.

Move rock wall  
to opposite side

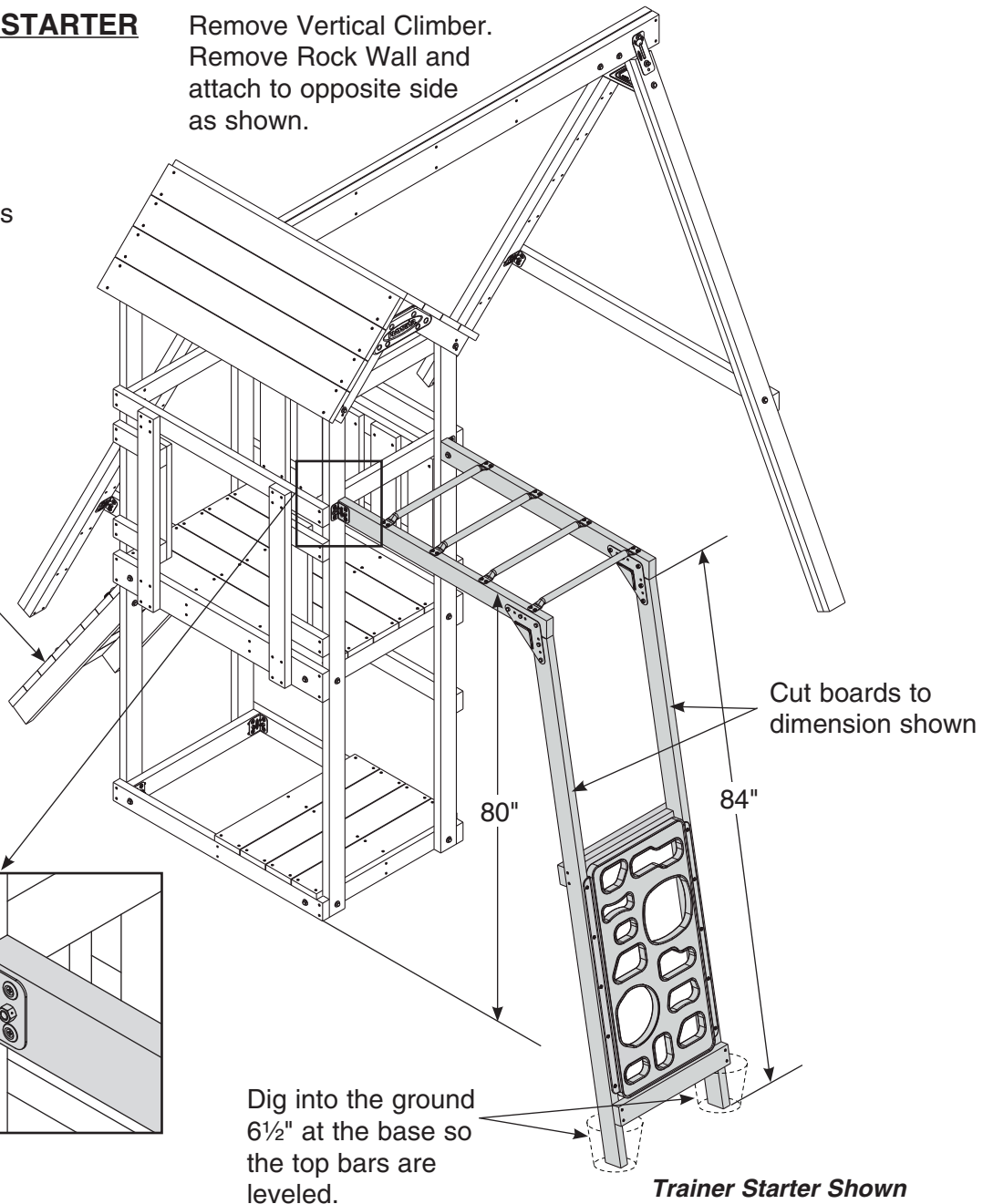
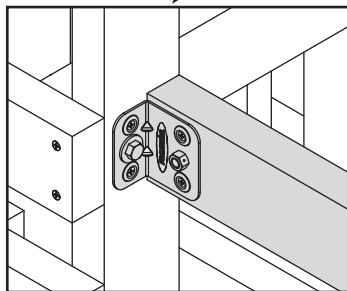

### **Attach Climbing Bar Assembly**

Cut boards to a length of 84".

Lift Climbing Bar Assembly into an upright position at the dimension shown.

Dig into the ground 6½" at the base so the top bars are leveled.

Use the brackets as a drill guide and drill ⅛" holes 1" deep into the boards. Attach with #8 x 1¼" deck screws.

Drill a ¼" hole 2½" deep into the boards. Secure with a ⅜" x 3" lag screw and ⅜" washer.

**Go to page 32 for instructions  
to reattach Vertical Climber.**

**Go to page 35 for  
anchoring instructions.**

## **CONTENDER - GOLD, SILVER, BRONZE, STARTER**

Remove existing Monkey Rings and attachment hardware.

### **Items for this STEP:**

- (4) Climbing Bars
- (16) #14 x 1¼" pan head screws

**NO swinging elements, including Monkey Rings, should be attached to overhead Climbing Bars since they pose a conflicting/fall hazard.**

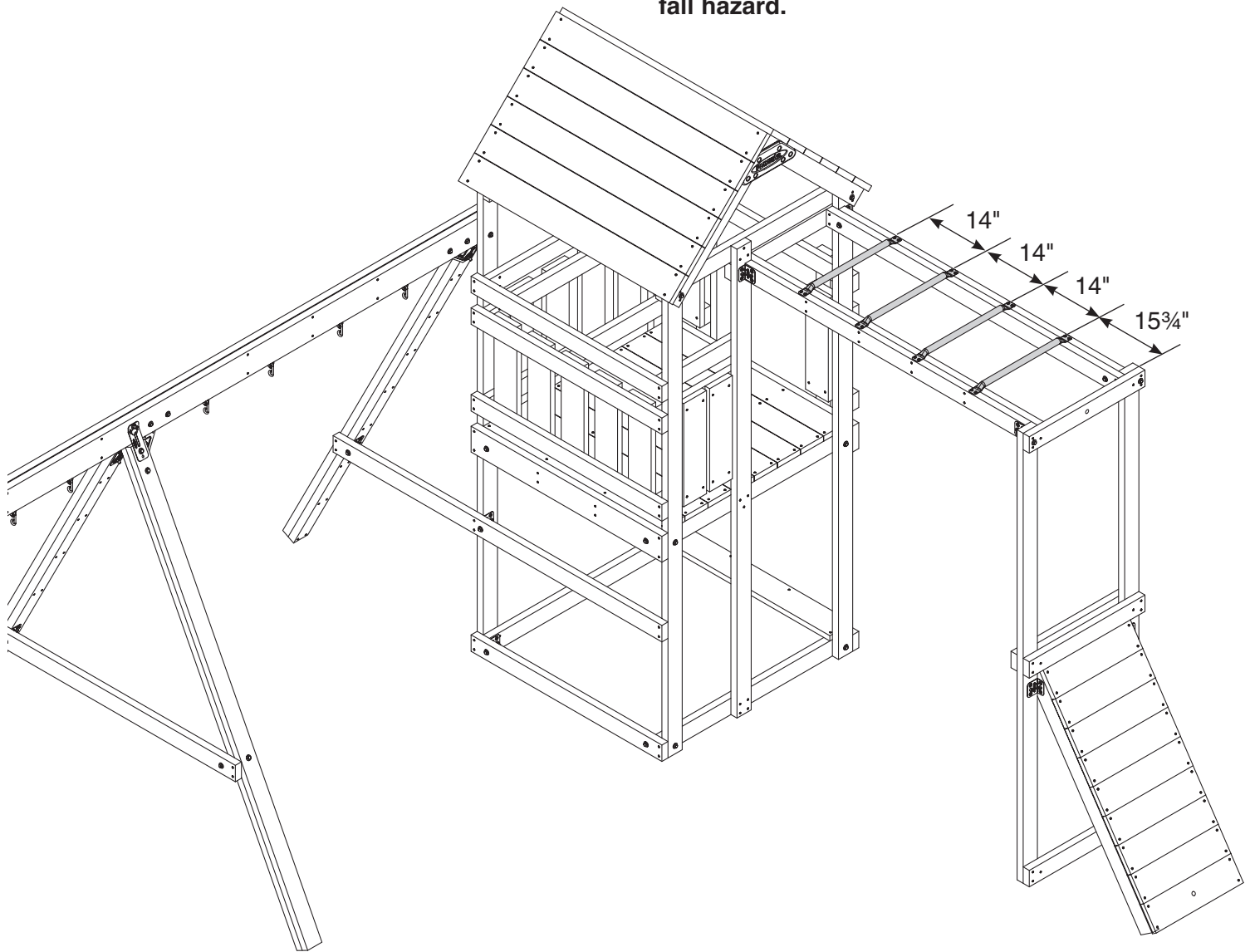

***Contender Starter Shown***

Attach Climbing Bars at dimensions shown.

Use the Climbing Bar as a drill guide and drill 1/8" holes 1" deep in the boards.

Attach with #14 x 1¼" pan head screws.

### **IMPORTANT:**

**The Climbing Bars must be positioned as specified, otherwise a head entrapment could exist.**



## LEGACY - SILVER

Remove Climbing Wall.

### Items for this STEP:

- (4) #8 x 1¼" deck screws
- (2) ⅜" x 3" lag screws
- (2) ⅜" washers

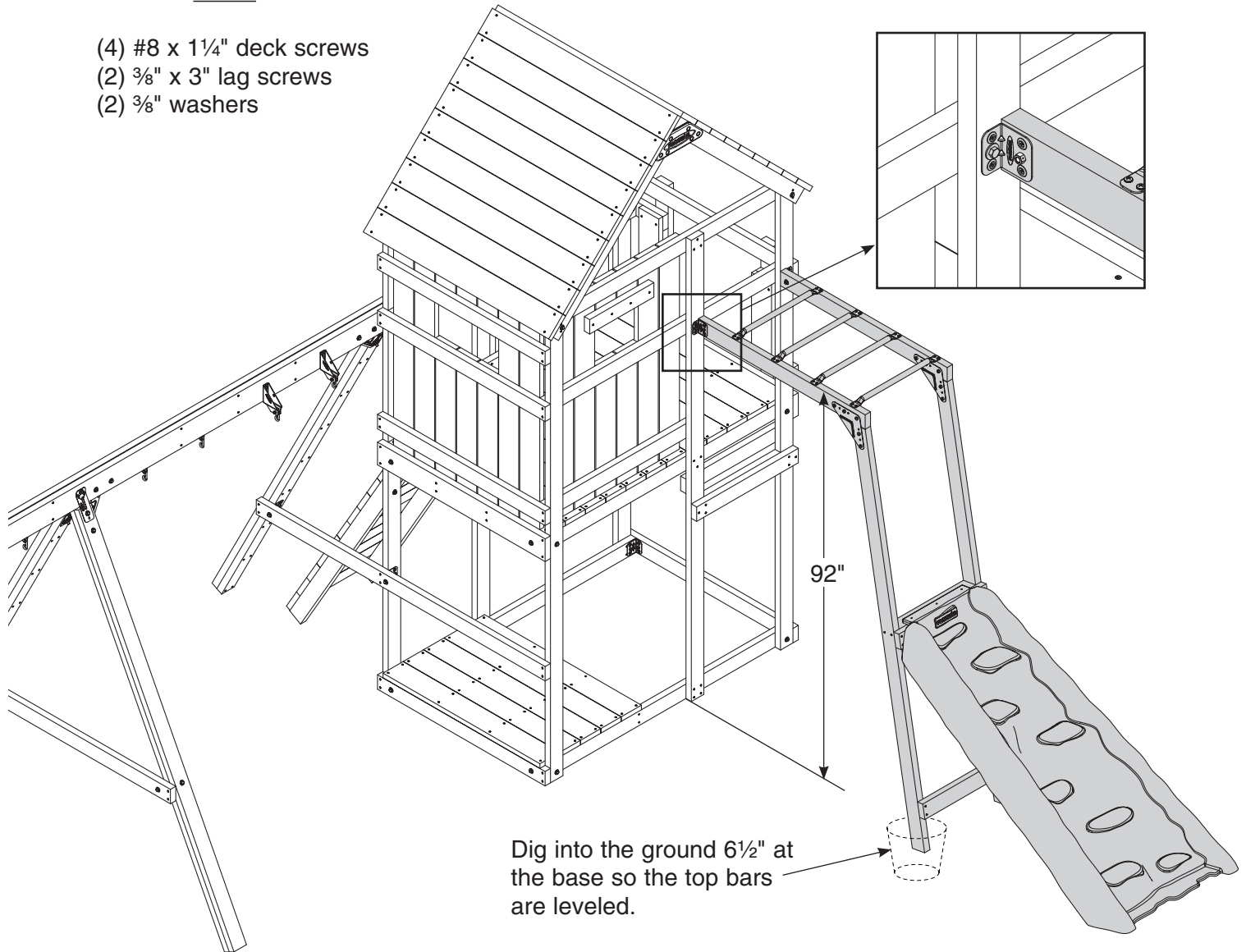

### Attach Climbing Bar Assembly

Lift Climbing Bar Assembly into an upright position at the dimension shown.

Dig into the ground about 6½" at the base so the top bars are leveled.

Use the brackets as a drill guide and drill ⅛" holes 1" deep into the boards. Attach with #8 x 1¼" deck screws.

Drill a ¼" hole 2½" deep into the boards. Secure with ⅜" x 3" lag screw and ⅜" washer.

Go to page 28 for instructions to reattach Climbing Wall.

Go to page 35 for anchoring instructions.

## **LEGACY - BRONZE**

Remove Climbing Steps.

### **Items for this STEP:**

- (4) #8 x 1 1/4" deck screws
- (2) 3/8" x 3" lag screws
- (2) 3/8" washers

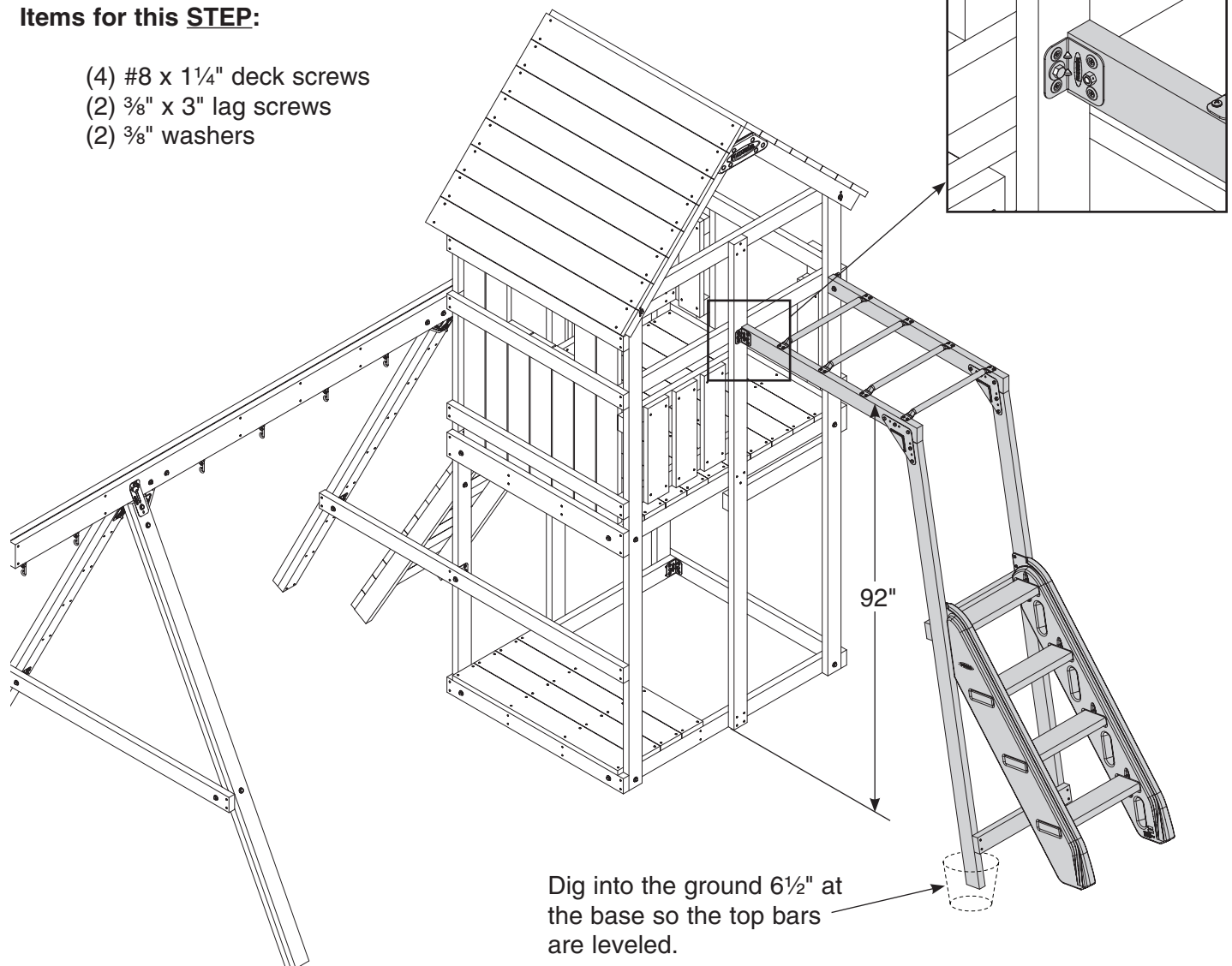

### **Attach Climbing Bar Assembly**

Lift Climbing Bar Assembly into an upright position at the dimension shown.

Dig into the ground about 6 1/2" at the base so the top bars are leveled.

Use the brackets as a drill guide and drill 1/8" holes 1" deep into the boards. Attach with #8 x 1 1/4" deck screws.

Drill a 1/4" hole 2 1/2" deep into the boards. Secure with 3/8" x 3" lag screw and 3/8" washer.

**Go to page 30 for instructions to reattach Climbing Steps.**

**Go to page 35 for anchoring instructions.**

## LEGACY - STARTER

Remove Vertical Climber.

### Items for this STEP:

- (4) #8 x 1¼" deck screws
- (2) ⅜" x 3" lag screws
- (2) ⅜" washers

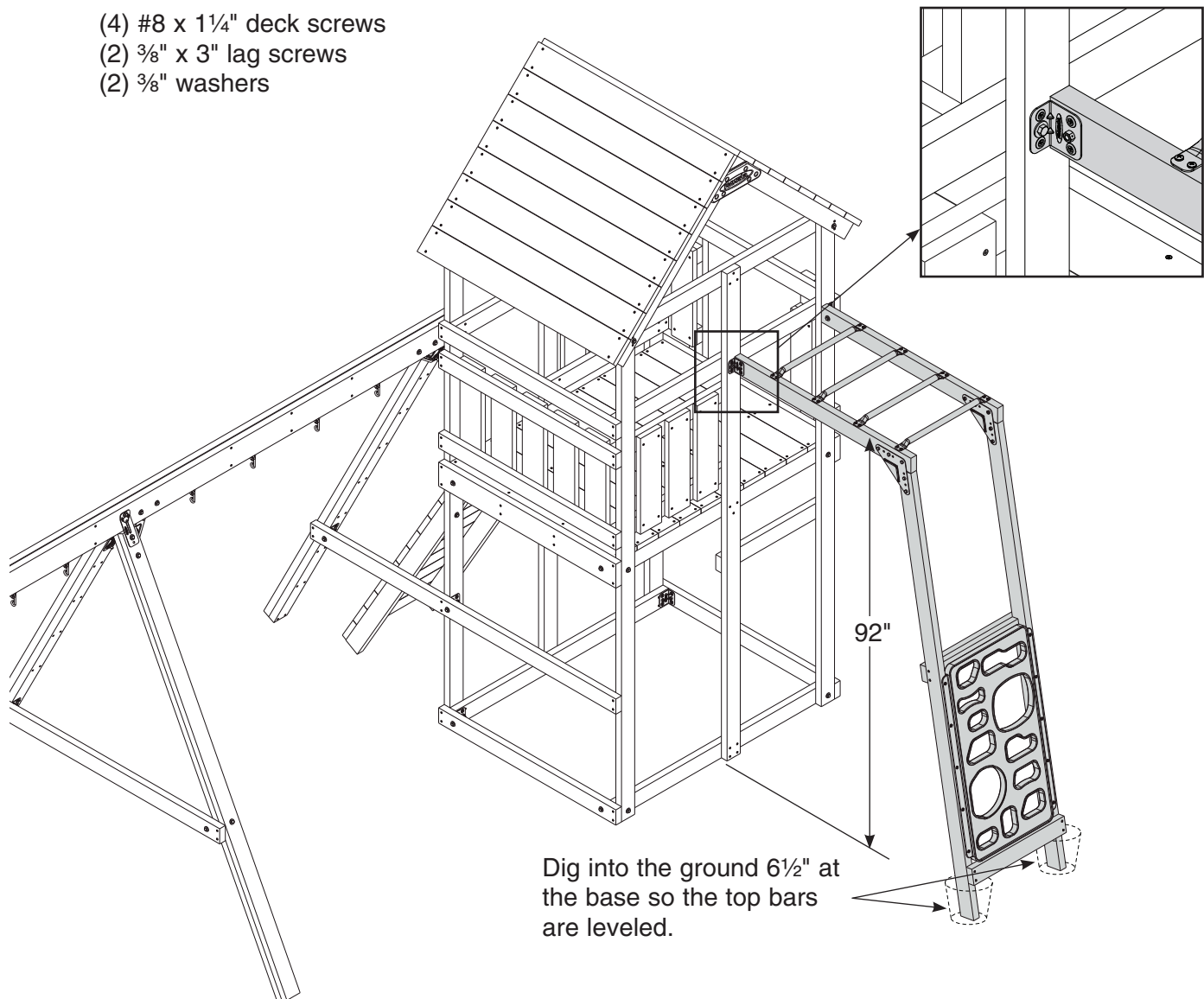

### Attach Climbing Bar Assembly

Lift Climbing Bar Assembly into an upright position at the dimension shown.

Dig into the ground about 6½" at the base so the top bars are leveled.

Use the brackets as a drill guide and drill ⅛" holes 1" deep into the boards. Attach with #8 x 1¼" deck screws.

Drill a ¼" hole 2½" deep into the boards. Secure with ⅜" x 3" lag screw and ⅜" washer.

**Go to page 32 for instructions to reattach Vertical Climber.**

**Go to page 35 for anchoring instructions.**

## **SUPER STAR XP - GOLD**

Remove existing Monkey Rings and attachment hardware.

### **Items for this STEP:**

- (4) Climbing Bars
- (16) #14 x 1¼" pan head screws

**NO swinging elements, including Monkey Rings, should be attached to overhead Climbing Bars since they pose a conflicting/fall hazard.**

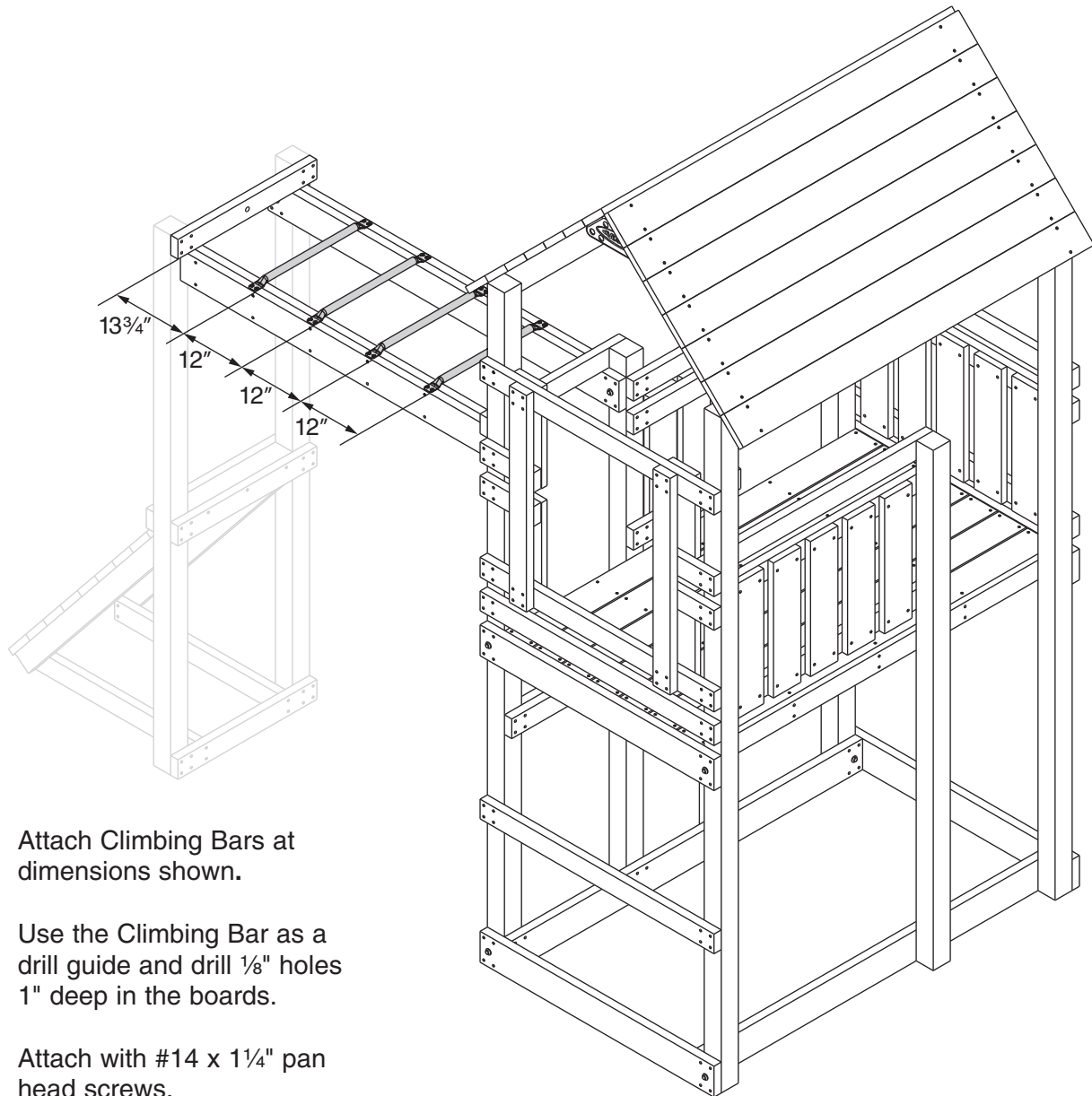

Attach Climbing Bars at dimensions shown.

Use the Climbing Bar as a drill guide and drill 1/8" holes 1" deep in the boards.

Attach with #14 x 1¼" pan head screws.

### **IMPORTANT:**

**The Climbing Bars must be positioned as specified, otherwise a head entrapment could exist.**

## **SUPER STAR XP - SILVER, BRONZE**

Remove existing Monkey Rings and attachment hardware.

### **Items for this STEP:**

- (4) Climbing Bars
- (16) #14 x 1¼" pan head screws

**NO** swinging elements, including Monkey Rings, should be attached to overhead Climbing Bars since they pose a conflicting/fall hazard.

### **IMPORTANT:**

The Climbing Bars must be positioned as specified, otherwise a head entrapment could exist.

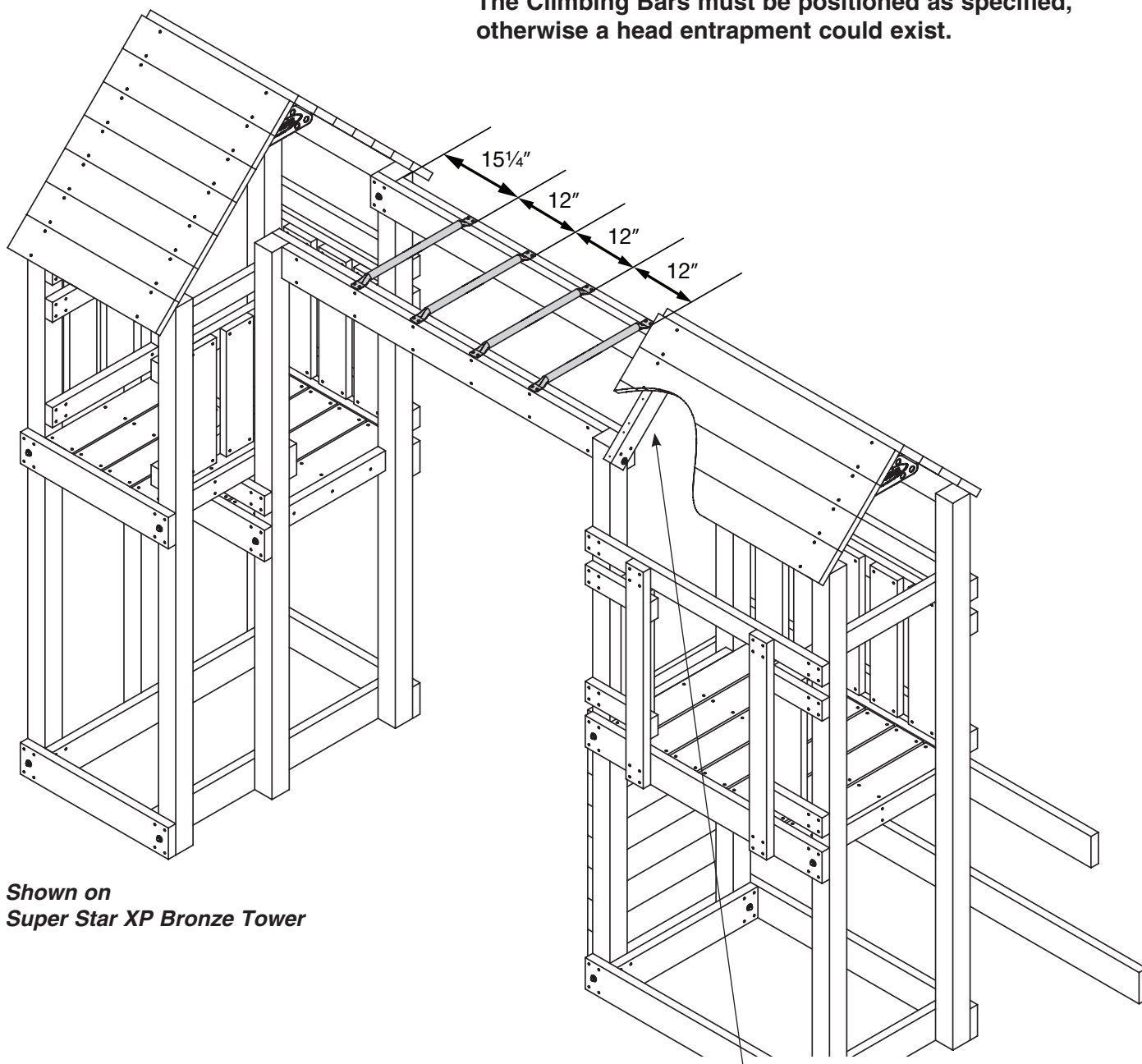

**Shown on  
Super Star XP Bronze Tower**

Remove 2" x 4" x 28½" horizontal board (not shown) from this area so no entrapment hazard is created when Climbing Bars are attached.

Attach Climbing Bars at dimensions shown. Use the Climbing Bar as a drill guide and drill ⅛" holes 1" deep in the boards.

Attach with #14 x 1¼" pan head screws.

## **VARSITY - GOLD & SILVER**

### **Items for this STEP:**

- (4) #8 x 1¼" deck screws
- (2) ⅜" lock nuts
- (4) ⅜" washers
- (2) ⅜" x 3½" hex bolts included with original PlayStar Playset.

### **Gold Only**

Remove Slide.

Remove Climbing Wall

Reattach Slide to tunnel deck where Climbing Wall was attached. Follow instructions provided with your slide.

### **Silver Only**

Remove Vertical Climber.

### **Attach Climbing Bar Assembly**

Cut boards to a length of 80".

Lift Climbing Bar Assembly into an upright position at the dimension shown.

Dig into the ground 6½" at the base so the top bars are leveled.

Use the brackets as a drill guide and drill ⅜" holes 1" deep into the boards. Attach with #8 x 1¼" deck screws.

Drill a ⅜" hole completely through the board. Secure with ⅜" x 3½" hex bolt, ⅜" washer and ⅜" lock nut.

**Go to page 28 for instructions to reattach Climbing Wall, or to page 32 for Vertical Climber.**

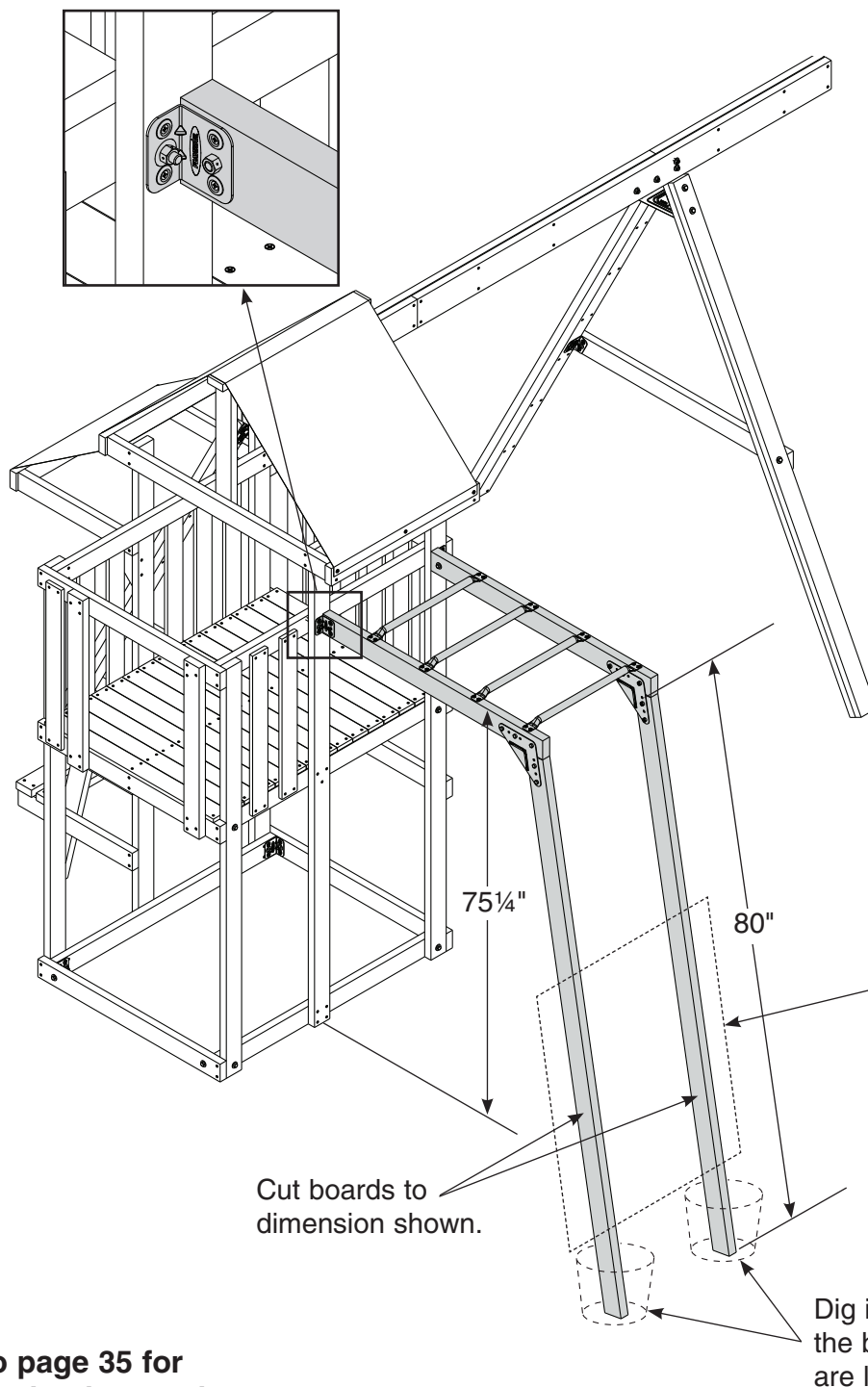

**Go to page 35 for anchoring instructions.**

**Items for this STEP:**

- (4) #8 x 1¼" deck screws
- (2) ⅜" x 2" hex bolts
- (2) ⅜" lock nuts
- (2) ⅜" washers

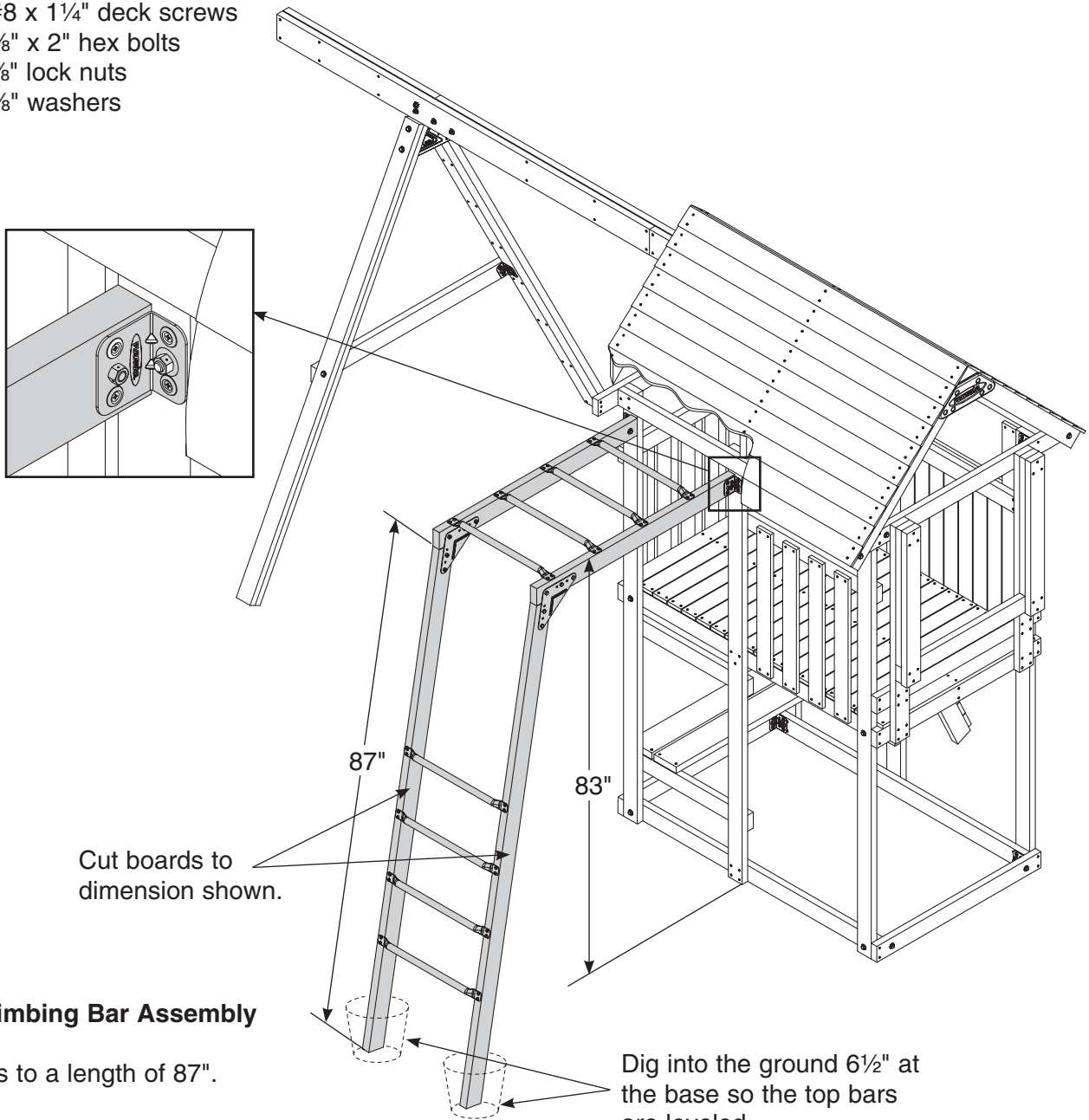

**Attach Climbing Bar Assembly**

Cut boards to a length of 87".

Lift Climbing Bar Assembly into an upright position at the dimension shown, making sure it is centered in the opening.

Dig into the ground 6½" at the base so the top bars are leveled.

Use the brackets as a drill guide and drill ⅛" holes 1" deep into the boards. Attach with #8 x 1¼" deck screws.

Drill a ⅜" hole completely through the boards. Secure with ⅜" x 2" hex bolt, ⅜" washer and ⅜" lock nut.

**Go to page 27 for instructions to reattach Climbing Bars.**

**Go to page 35 for anchoring instructions.**

## **ALL-PRO - BRONZE & STARTER**

### **Items for this STEP:**

- (4) #8 x 1¼" deck screws
- (2) ⅜" x 2" hex bolts
- (2) ⅜" lock nuts
- (2) ⅜" washers

Remove Slide.

Remove existing Climbing Bars from tower.

Remove 2" x 4" x 38¾" board.

Reattach Slide to tower opening where Climbing Bars were attached.

Follow instructions provided with your Slide to attach to tower.

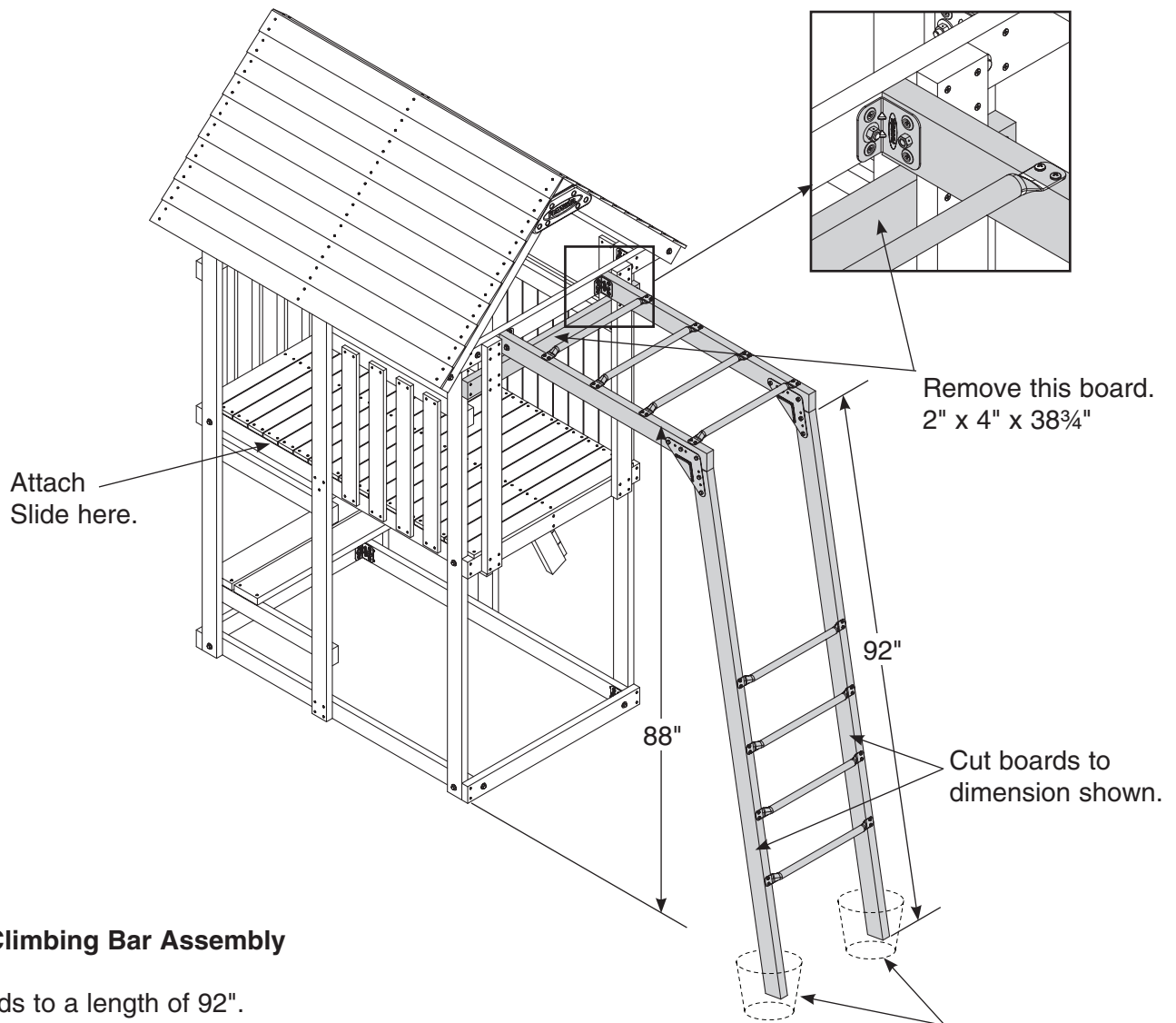

### **Attach Climbing Bar Assembly**

Cut boards to a length of 92".

Lift Climbing Bar Assembly into an upright position at the dimension shown, making sure it is centered in the opening.

Dig into the ground 6½" at the base so the top bars are leveled.

Use the brackets as a drill guide and drill ⅜" holes 1" deep into the boards. Attach with #8 x 1¼" deck screws.

Drill a ⅜" hole completely through the boards. Secure with ⅜" x 2" hex bolt, ⅜" washer and ⅜" lock nut.

**Go to page 27 for instructions to reattach Climbing Bars.**

**Go to page 35 for anchoring instructions.**



**Items for this STEP:**

- (4) #8 x 1¼" deck screws
- (2) ⅜" x 2" hex bolts
- (2) ⅜" lock nuts
- (2) ⅜" washers

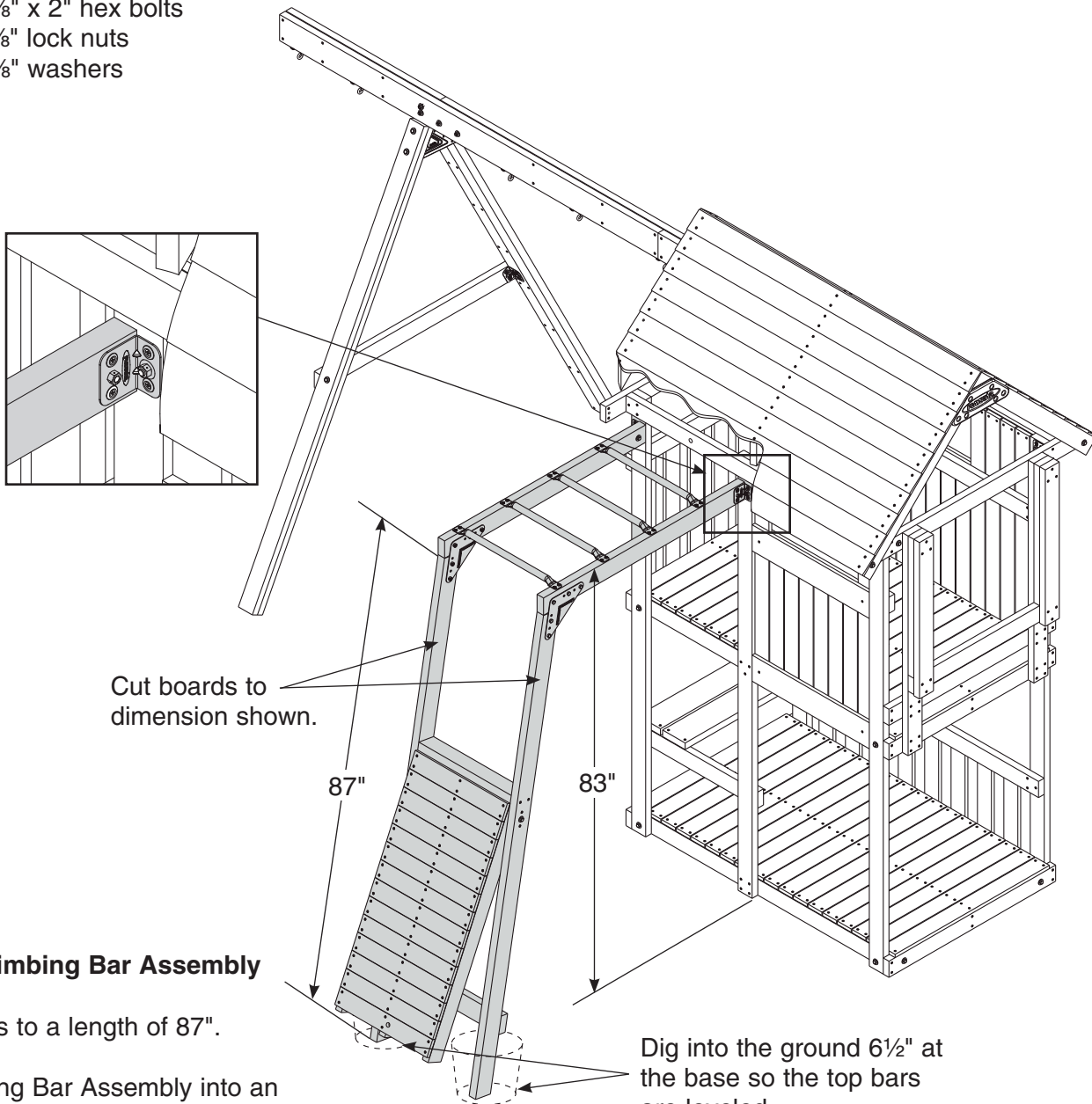

Cut boards to dimension shown.

87"

83"

**Attach Climbing Bar Assembly**

Cut boards to a length of 87".

Lift Climbing Bar Assembly into an upright position at the dimension shown, making sure it is centered in the opening.

Dig into the ground 6½" at the base so the top bars are leveled.

Dig into the ground 6½" at the base so the top bars are leveled.

Use the brackets as a drill guide and drill ⅛" holes 1" deep into the boards. Attach with #8 x 1¼" deck screws.

Drill a ⅜" hole completely through the boards. Secure with ⅜" x 2" hex bolt, ⅜" washer and ⅜" lock nut.

**Go to page 34 for instructions to reattach Wood Rock Wall.**

**Go to page 35 for anchoring instructions.**

## GRAND SLAM - BRONZE

### Items for this STEP:

- (4) #8 x 1 1/4" deck screws
- (2) 3/8" x 2" hex bolts
- (2) 3/8" lock nuts
- (2) 3/8" washers

Remove Slide.

Remove 2" x 4" x 38 3/4" board.

Reattach Slide to Adventure Tunnel. Follow instructions provided with your Slide to attach to tunnel.

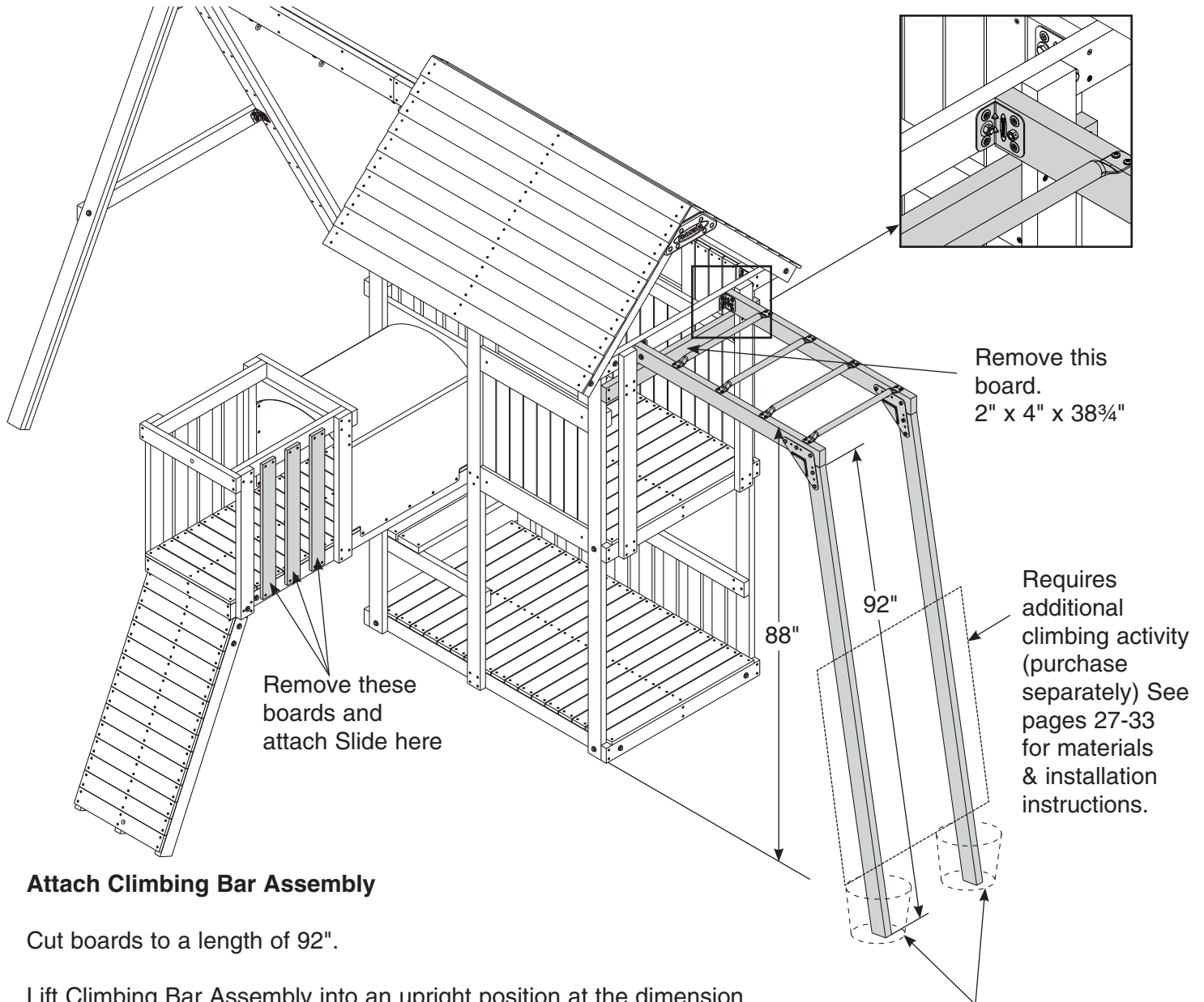

Remove these boards and attach Slide here

Remove this board.  
2" x 4" x 38 3/4"

Requires additional climbing activity (purchase separately) See pages 27-33 for materials & installation instructions.

Dig into the ground 6 1/2" at the base so the top bars are leveled.

### Attach Climbing Bar Assembly

Cut boards to a length of 92".

Lift Climbing Bar Assembly into an upright position at the dimension shown, making sure it is centered in the opening.

Dig into the ground 6 1/2" at the base so the top bars are leveled.

Use the brackets as a drill guide and drill 1/8" holes 1" deep into the boards. Attach with #8 x 1 1/4" deck screws.

Drill a 3/8" hole completely through the boards. Secure with 3/8" x 2" hex bolt, 3/8" washer and 3/8" lock nut.

Go to pages 27-33 for instructions to attach Climbing Activity.

Go to page 35 for anchoring instructions.

# ACCESSORY ATTACHMENTS

## CLIMBING BARS

These Climbing Bars may or may not be from existing playset. Attach Climbing Bars at dimensions from ground as shown.

### **IMPORTANT:**

***The Climbing Bars must be positioned as specified, otherwise a head entrapment could exist.***

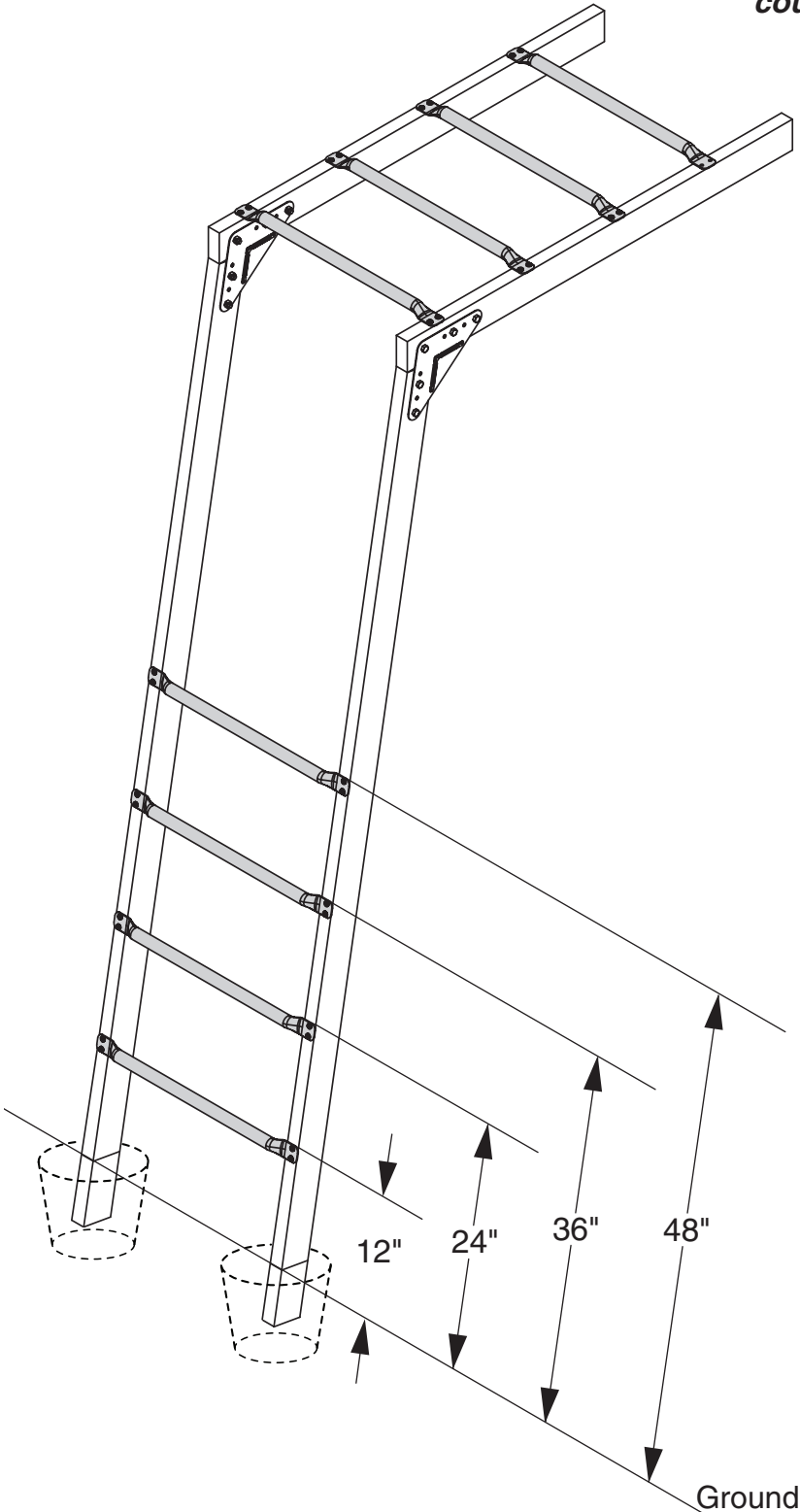

**Go to page 35 for anchoring instructions.**

## CLIMBING WALL

### Items for this STEP:

- (2) 2" x 4" x 24½" board
- (1) 2" x 4" x 21½" board
- (15) #8 x 2½" deck screws

Use the screws provided to attach the three boards at the dimensions shown.

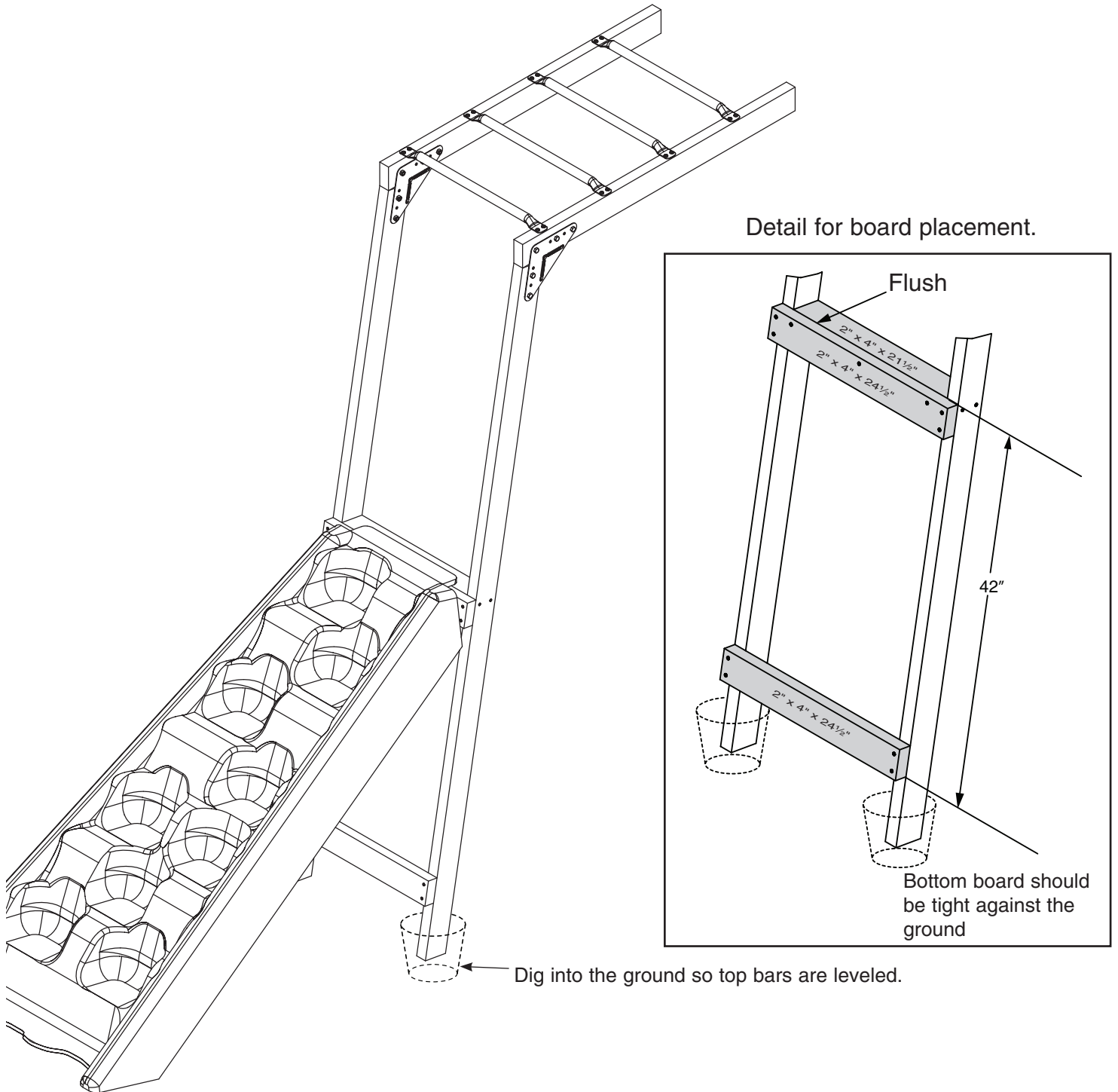

Go to page 35 for anchoring instructions.

1. Align top of Climbing Wall at right angle 90°). Lip of climbing wall should rest on the play deck 1½". Using the Climbing Wall as a template, mark play deck through the three holes in the climbing wall. Drill three ⅜" holes at marked locations. **(Fig. 1)**
2. Attach Climbing Wall temporarily to play deck with three #14 x 1¼" pan head screws provided.
3. Prepare level area where Climbing Wall touches ground.
4. Locate and mark the ground on the back side and in center of Climbing Wall. Remove Climbing Wall and screw Playset Anchor into the ground (a long screwdriver will help). Screw the anchor deep enough so that the center of the loop at the top of the anchor will be approximately 3½" off ground when wall is in the final position.

5. Reinstall Climbing Wall permanently, attaching it to play deck using #14 x 1¼" pan head screws provided.
6. Use the anchor as a drill guide and drill a ⅜" hole completely through the Climbing Wall. Attach Climbing Wall to anchor with one ⅜" x 1¼" hex bolt, two ⅜" washers and one ⅜" lock nut provided in the anchor kit. **(Fig. 2)**

***Warning: Failure to anchor the Climbing Wall properly could cause serious injury from children lifting the Unit.***

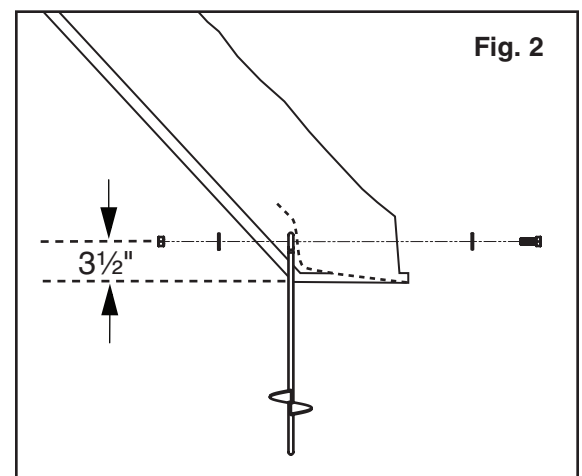
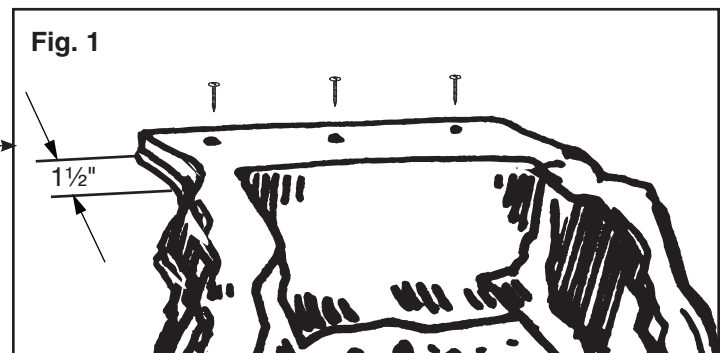
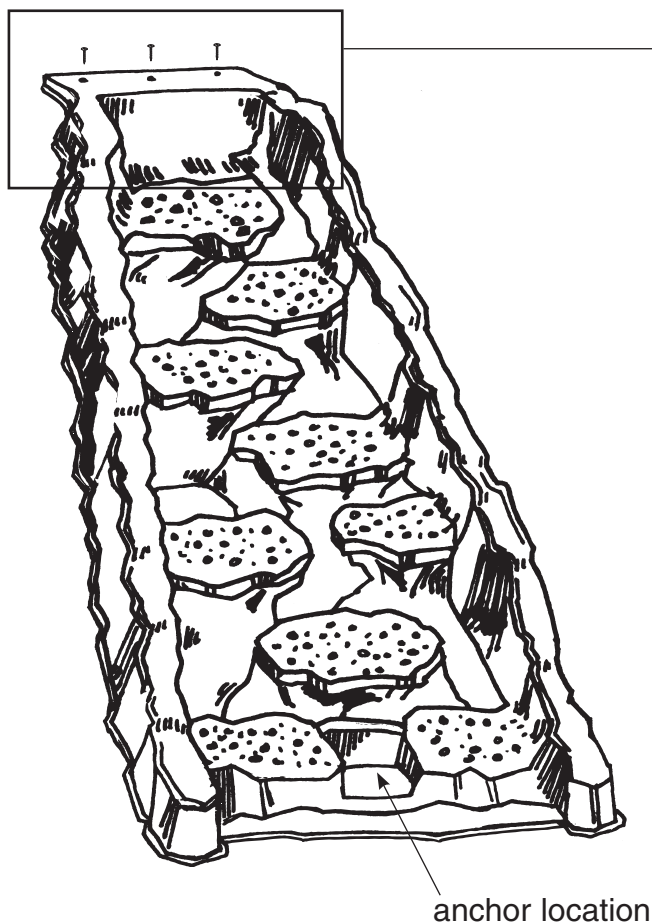

## CLIMBING STEPS

### Items for this STEP:

- (2) 2" x 4" x 24½" board
- (8) #8 x 2½" deck screws

Use the screws provided to attach the two boards at the dimensions shown.

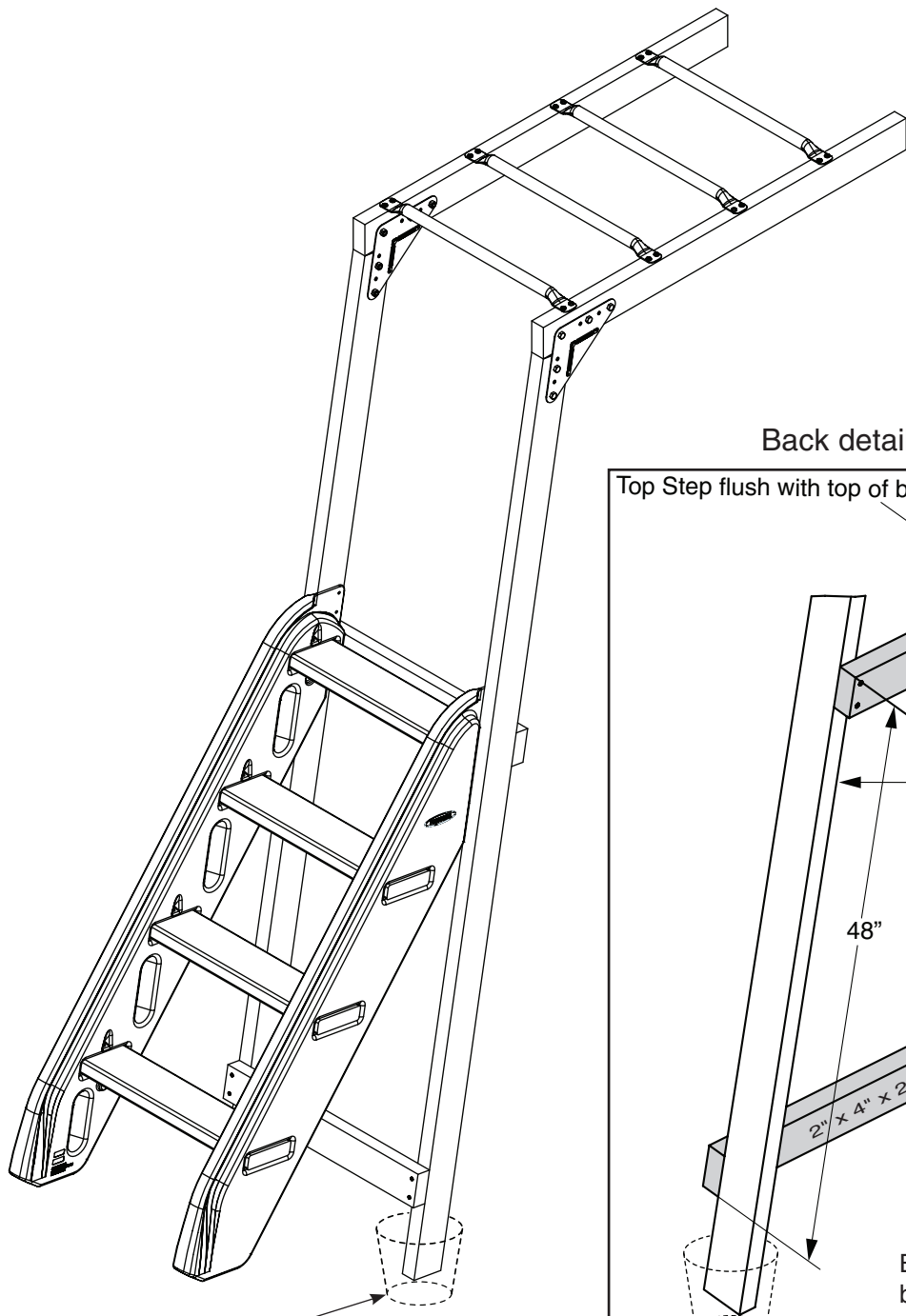

Dig into the ground so top bars are leveled.

### Back detail for board placement.

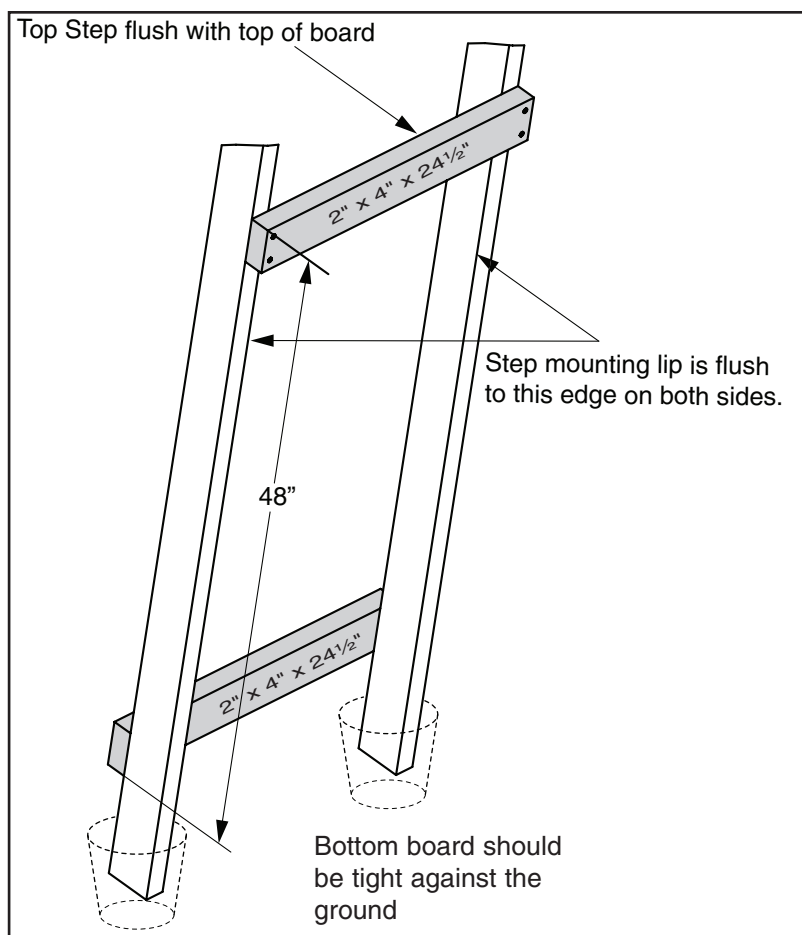

Go to page 35 for anchoring instructions.

1. Place the left (L) step side rail on a flat work surface. Insert one 2" x 6" x 21" top step into the top hole.

**Note:** *This hole does not go completely through the side rail.*

2. Insert three 2" x 6" x 23½" standard steps into the remaining holes until they are flush with the outside of the side rail. **(Fig. 1)**

3. Insert the right (R) step side rail on top of the existing boards until the standard boards are flush with the outside of the side rail. **(Fig. 2)**

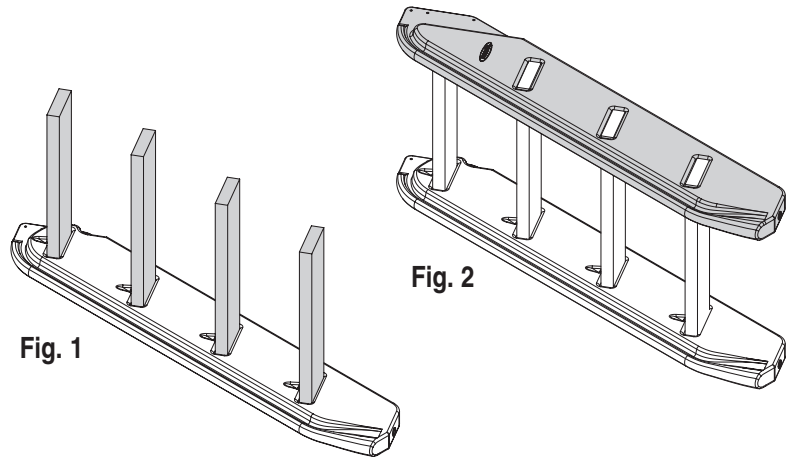

4. Position the Climbing Steps Assembly into the 21½" opening of your play deck so that the top surface of the top step is 12" from the top surface of your play deck (48" from the ground). Secure the Climbing Step Assembly to the play deck using three #14 x 1¼" pan head screws on each side as shown. **(Fig. 3)**

**NOTE:** *The steps must be positioned as specified. The gaps must not exceed 3½" otherwise a head entrapment could exist.*

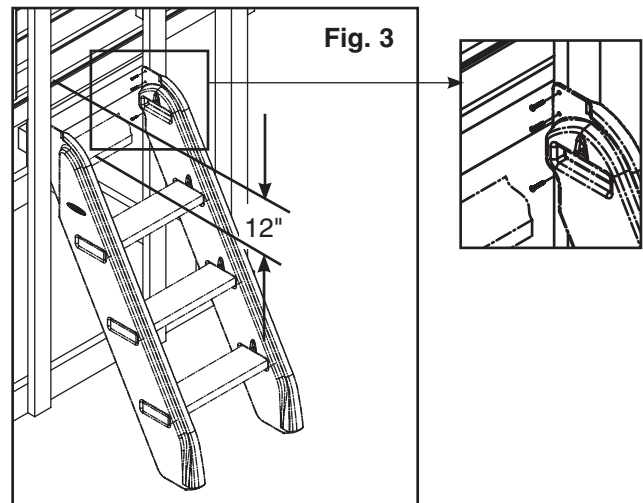

6. Making sure that all of the standard steps are flush with the outside sides of the Climbing Steps Assembly, secure each step to the side rails using two #14 x 1¼" pan head screws for each step as shown. **(Fig. 4)**

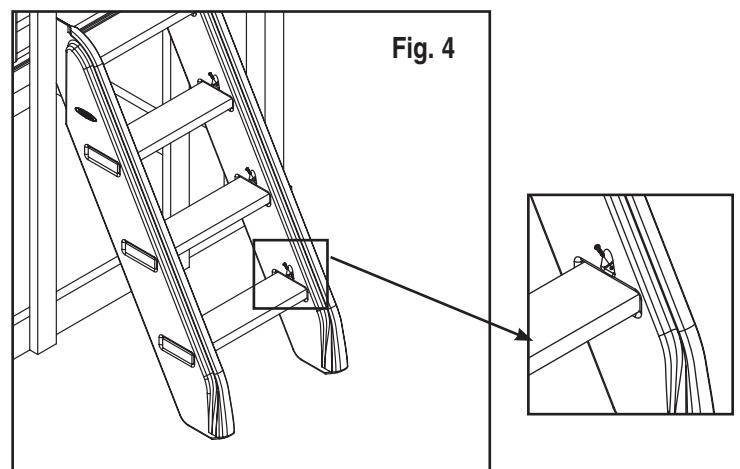

## **VERTICAL CLIMBER**

### **Items for this STEP:**

- (2) 2" x 4" x 24½" board
- (1) 2" x 4" x 21½" board
- (15) #8 x 2½" deck screws

Use the screws provided to attach the three boards at the dimensions shown.

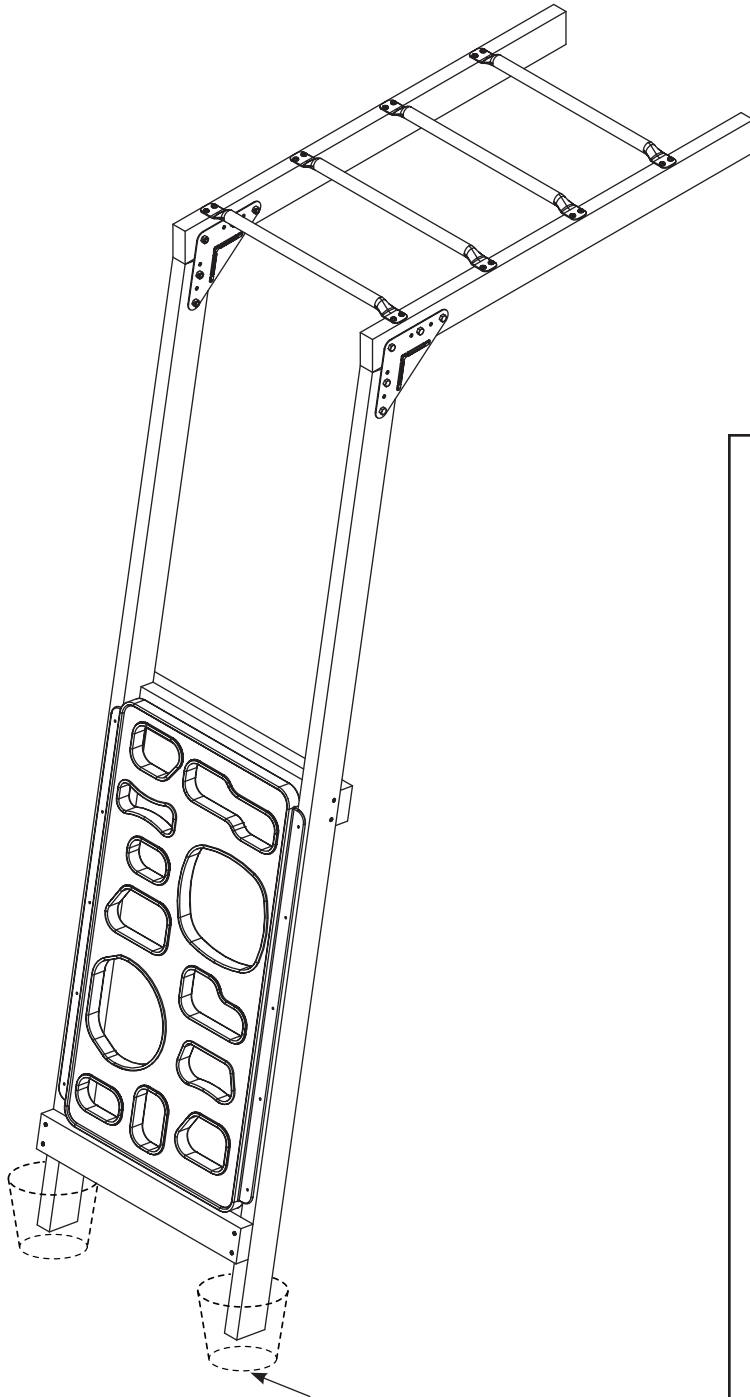

Dig into the ground so top bars are leveled.

Back detail for board placement.

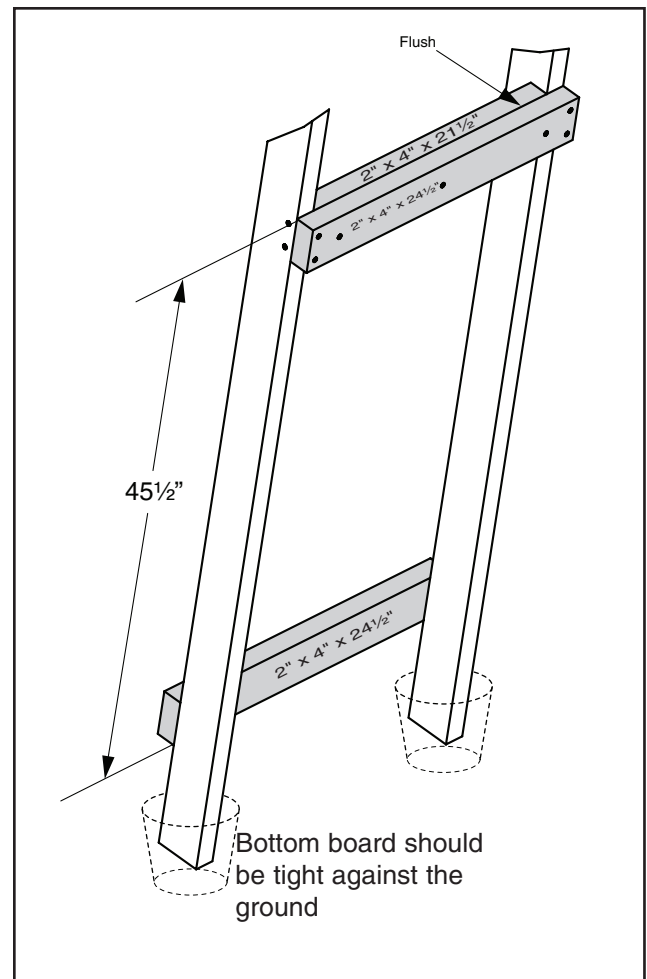

**Go to page 35 for anchoring instructions.**



## **VERTICAL CLIMBER Cont.**

1. Position Vertical Climber so that the top is flush with the top of the deck and mark pilot holes.
2. Drill  $\frac{1}{8}$ " holes 1" deep into the board.
3. Attach with five #14 x  $1\frac{1}{4}$ " pan head screws (provided) on each side.

**Caution:** *Gap between Vertical Climber and playset must not exceed  $3\frac{1}{2}$ " or a head entrapment could exist.*

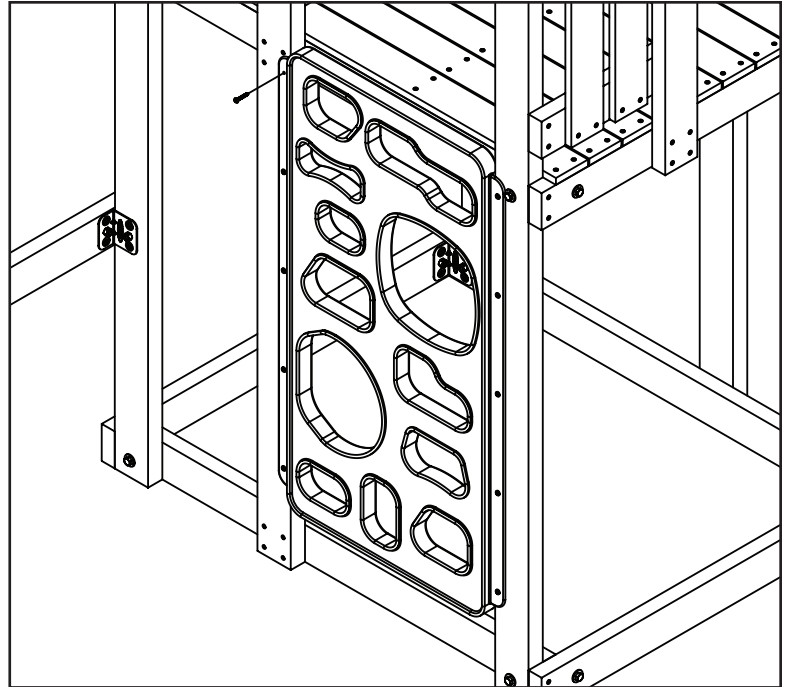

## **Slide**

### **Scoop Slide - PS 8813**

1. Align Slide at right angle ( $90^\circ$ ) to 48" play deck. Lip of Slide should rest on the play deck  $1\frac{1}{2}$ ". Using the Slide as a template, mark play deck through the three holes in the slide. Drill three  $\frac{1}{8}$ " holes at marked location.
2. Attach Slide temporarily to play deck with three #14 x  $1\frac{1}{4}$ " screws provided.
3. Prepare level area where Slide touches ground that is 1" below surrounding grade.
4. Locate and mark the ground on the back side, on either side of the star. Remove Slide and screw Playset Anchor into the ground (a long screwdriver will help). Screw the anchor deep enough so that the loop at the top of the anchor will be flat against the back surface of Slide when the Slide is in the final position.
5. Reinstall Slide permanently, attaching it to play deck using #14 x  $1\frac{1}{4}$ " pan head screws provided.
6. Use the Playset Anchor as a drill guide and drill a  $\frac{3}{8}$ " hole completely through the Slide. Attach Slide to anchor with one  $\frac{3}{8}$ " x  $1\frac{1}{4}$ " hex bolt, two  $\frac{3}{8}$ " washers and one  $\frac{3}{8}$ " lock nut provided in the anchor kit.
7. Fill in around bottom of Slide to make surface level to surrounding grade.

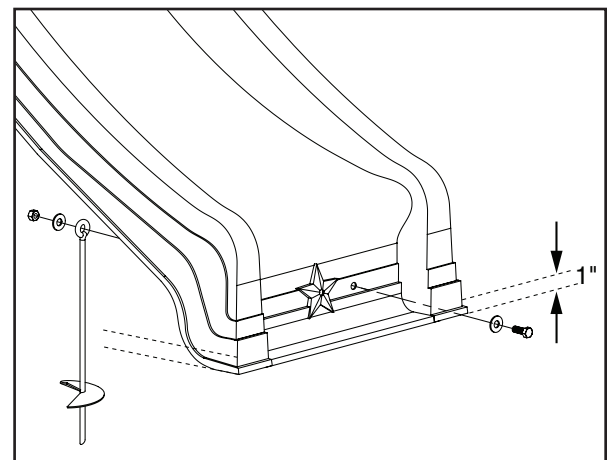
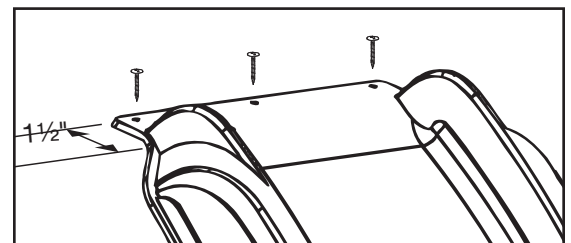

**Caution:** *Failure to anchor the Slide properly could cause serious injury from children lifting the Slide.*

**Caution:** *Do not install this Slide over concrete, asphalt, packed earth, or any other hard surface. A fall onto a hard surface can result in serious injury to the equipment user.*

## WOOD ROCK WALL

### Item for this STEP:

- (1) 2" x 4" x 21½" board
  - (1) 2" x 4" x 24½" board
  - (12) #8 x 2½" deck screws
  - (2) ⅜" x 3½" galvanized hex bolts
  - (2) ⅜" galvanized washers
  - (2) ⅜" galvanized nuts
- } Purchase Separately

### Relocate Wood Rock Wall from tower.

Use the screws provided to attach the two boards at the dimensions shown.

Attach Wood Rock Wall as shown using #8 x 3½" deck screws, ⅜" x 3½" hex bolts, ⅜" washers, and ⅜" nuts. See detail.

Reattach Playset Anchor to Wood Rock Wall following directions provided with your original PlayStar instructions.

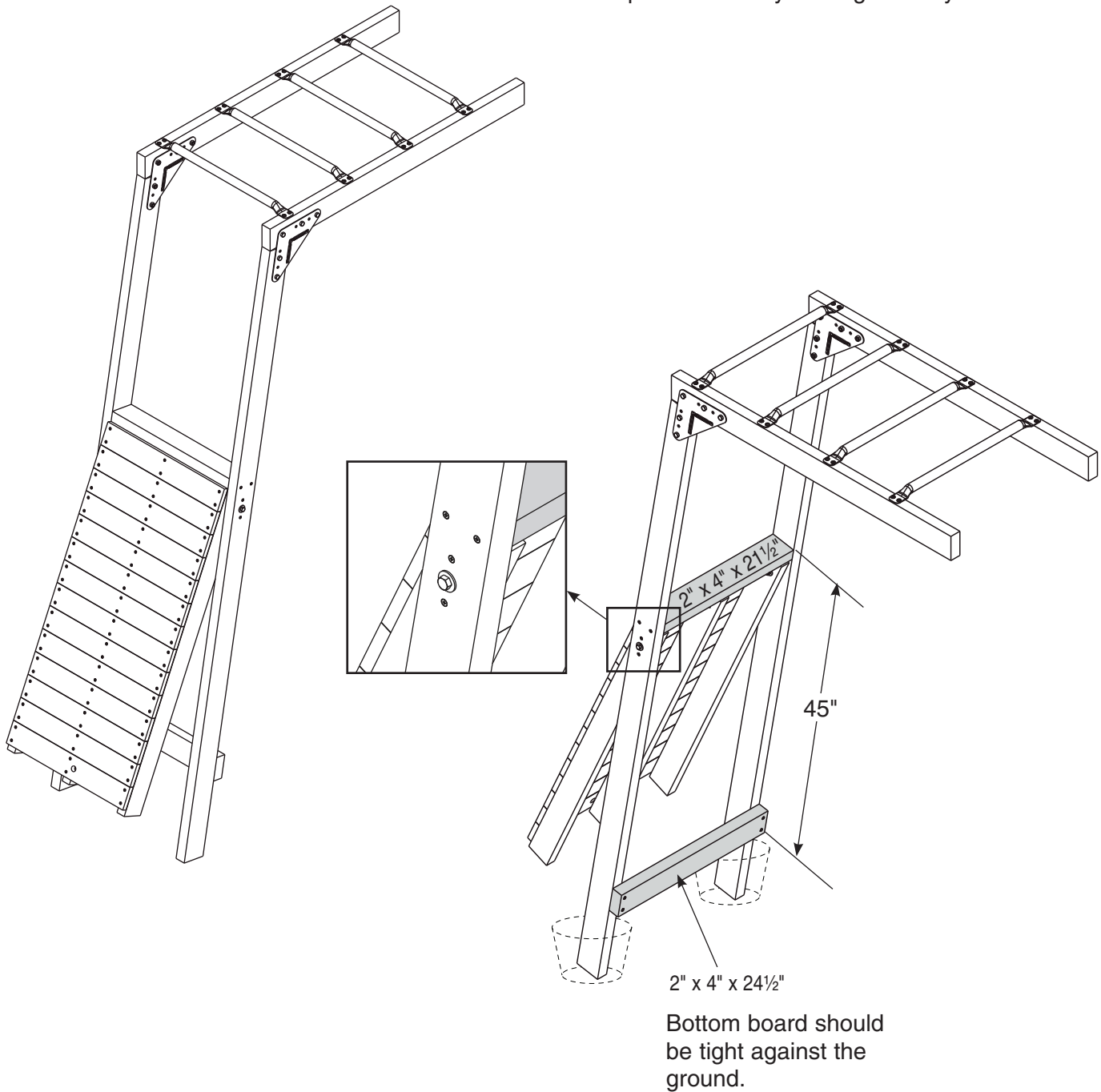

Go to page 35 for anchoring instructions.

## **ANCHORING**

### **Items for this STEP:**

- (1) Playset Anchors PS 7690 (sold separately)
- (2)  $\frac{3}{8}$ " x 2" lag screws (provided with PS 7690)
- (2)  $\frac{3}{8}$ " washers (provided with PS 7690)

At locations shown screw Playset Anchors into ground by hand (a long screwdriver will help).

Use the anchor as a drill guide and drill a  $\frac{1}{4}$ " hole 1" deep into the board. Attach with  $\frac{3}{8}$ " x 2" lag screw and  $\frac{3}{8}$ " washer.

***Note: If soil conditions permit anchors to be pulled out easily, such as in sandy soil conditions, cementing is required. If your ground is too hard to screw in the anchors you can remove the earth with a shovel. Install the anchors and compact the earth as you replace it. Anchors must be placed below the level of the shock-absorbing surfacing material to prevent tripping or injury resulting from a fall.***

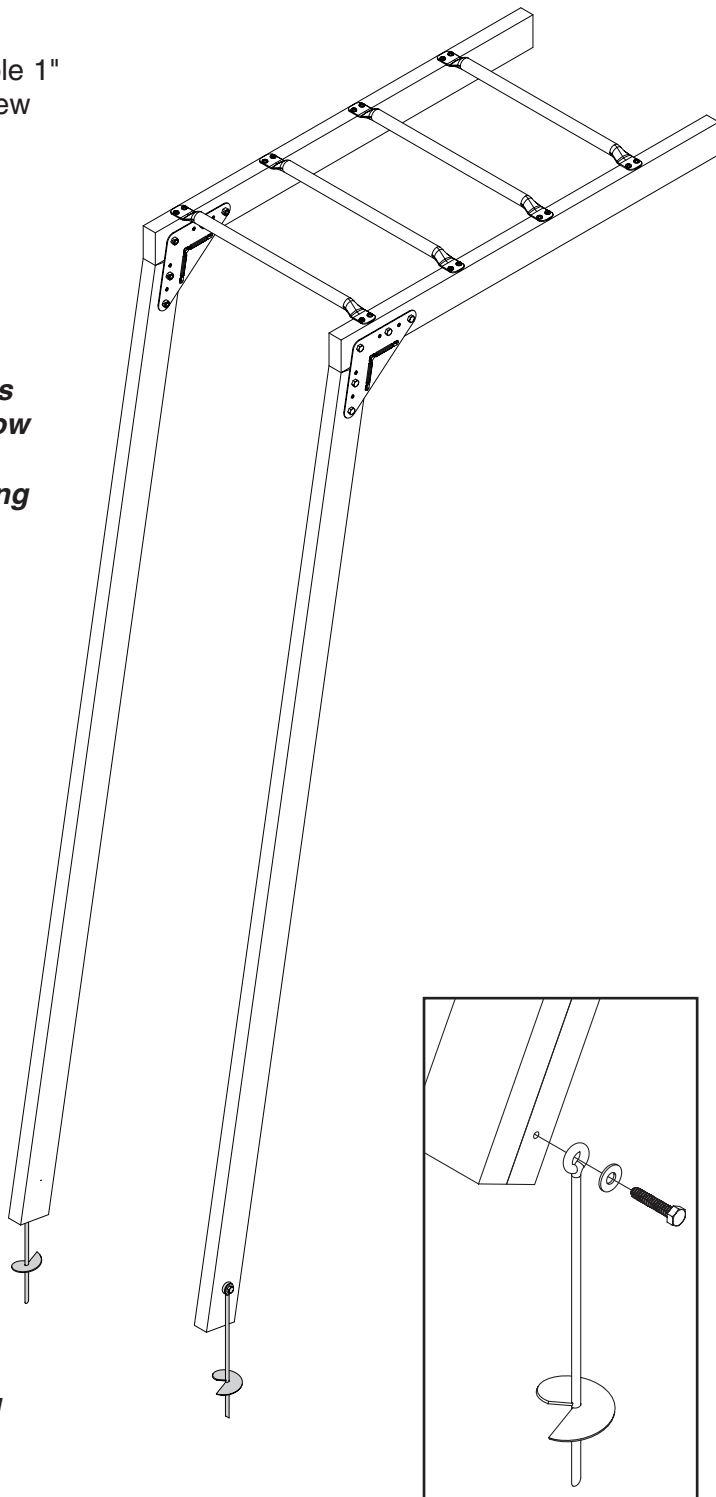

***Reminder:***  
***Be sure to install proper shock-absorbing surfacing material. Refer to the Safety Guidelines at the beginning of this plan.***



*Thank You for choosing PlayStar. Because it is our intention to make this a positive family experience, we have taken great care in preparing this product. Should you have any questions, or if we can assist you in any way, please call our friendly Customer Service Department for immediate action.*

Do not return to the store.  
**Please call us Toll Free at 1-888-PLAYSTAR**  
(752-9782)

Monday through Friday, 8:00 A.M. to 5:00 P.M. C.S.T.

Ask for Customer Service.

**We Will Gladly Help!**



PlayStar, Incorporated, Janesville, WI 53547

© 2014, 2009, 2007, PlayStar, Inc. Reproduction of this document in part or whole is prohibited without the permission of PlayStar, Inc.

Protected by one or more of the following United States or Foreign Patents: US D418,189; US D409,708; US D424,154; US D428,637; US 6,402,663; US D422,332; US D410,059; US 6,068,557; US 6,302,801; US 6,482,095; US 6,039,654; US D410,060; US D424,649; US 6,361,445; CA 2,304,345; US 6,540,645; US 6,709,365; US 6,942,600; US D513,779; US 6,991,550; CA D109,228; CA D109,224; CA D109,225; CA 2,304,113; US 6,629,907; US D517,636; US D518,530; US D520,590; US 520,591; US D534,613; US 7,186,183; US 7,189,034; US 7,253,951; US D548,760; US 7,304,810; CA D109,227; CA D109,226; CA D112,355; CA D113,437; CA D113,442; CA D114,067; CA D114,068; CA 2,304,896; CA D119,674; US D573,222; US 7,419,437; CA 2,304,068; CA 2,488,576; US D580,507; US D585,570; CA 2,490,923; CA 2,304,341; US 7,594,875; CA 2,304,043; CA 2,529,276; CA 2,633,628; CA 2,633,056; US 7,594,875; CA 2,498,701; CA 2,495,136; CA 2,488,600